



EOF3H54X
KOFGH54X

User Manual

Oven

Manual de instruções

Forno

Manual de instrucciones

Horno

EN 2

PT 27

ES 55



Electrolux



electrolux.com/register

WE'RE THINKING OF YOU

Thank you for purchasing an Electrolux appliance. You've chosen a product that brings with it decades of professional experience and innovation. Ingenious and stylish, it has been designed with you in mind. So whenever you use it, you can be safe in the knowledge that you'll get great results every time.

Welcome to Electrolux.

Visit our website to:



Get usage advice, brochures, trouble shooter, service and repair information:
www.electrolux.com/support



Register your product for better service:
www.registerelectrolux.com



Buy Accessories, Consumables and Original spare parts for your appliance:
www.electrolux.com/shop

CUSTOMER CARE AND SERVICE

Always use original spare parts.

When contacting our Authorised Service Centre, ensure that you have the following data available: Model, PNC, Serial Number.

The information can be found on the rating plate.

 Warning / Caution-Safety information

 General information and tips

 Environmental information

Subject to change without notice.

CONTENTS

1. SAFETY INFORMATION.....	3
2. SAFETY INSTRUCTIONS.....	4
3. INSTALLATION.....	6
4. PRODUCT DESCRIPTION.....	8
5. CONTROL PANEL.....	8
6. BEFORE FIRST USE.....	9
7. DAILY USE.....	10
8. CLOCK FUNCTIONS.....	11
9. USING THE ACCESSORIES.....	12
10. ADDITIONAL FUNCTIONS.....	13
11. HINTS AND TIPS.....	13
12. CARE AND CLEANING.....	22
13. TROUBLESHOOTING.....	25
14. ENERGY EFFICIENCY.....	25

1. ⚠ SAFETY INFORMATION

Before the installation and use of the appliance, carefully read the supplied instructions. The manufacturer is not responsible for any injuries or damage that are the result of incorrect installation or usage. Always keep the instructions in a safe and accessible location for future reference.

1.1 Children and vulnerable people safety

- This appliance can be used by children aged from 8 years and above and persons with reduced physical, sensory or mental capabilities or lack of experience and knowledge if they have been given supervision or instruction concerning the use of the appliance in a safe way and understand the hazards involved. Children of less than 8 years of age and persons with very extensive and complex disabilities shall be kept away from the appliance unless continuously supervised.
- Do not let children play with the appliance.
- Keep all packaging away from children and dispose of it appropriately.
- **WARNING:** Keep children and pets away from the appliance when it operates or when it cools down. Accessible parts become hot during use.
- If the appliance has a child safety device, it should be activated.
- Children shall not carry out cleaning and user maintenance of the appliance without supervision.

1.2 General Safety

- Only a qualified person must install this appliance and replace the cable.
- **WARNING:** The appliance and its accessible parts become hot during use. Care should be taken to avoid touching heating elements.
- Always use oven gloves to remove or put in accessories or ovenware.

- Before carrying out any maintenance, disconnect the appliance from the power supply.
- **WARNING:** Ensure that the appliance is switched off before replacing the lamp to avoid the possibility of electric shock.
- Do not use the appliance before installing it in the built-in structure.
- Do not use a steam cleaner to clean the appliance.
- Do not use harsh abrasive cleaners or sharp metal scrapers to clean the glass door since they can scratch the surface, which may result in shattering of the glass.
- If the mains power supply cable is damaged, it must be replaced by the manufacturer, its Authorised Service Centre or similarly qualified persons to avoid an electrical hazard.
- To remove the shelf supports first pull the front of the shelf support and then the rear end away from the side walls. Install the shelf supports in the opposite sequence.

2. SAFETY INSTRUCTIONS

2.1 Installation



WARNING!

Only a qualified person must install this appliance.

- Remove all the packaging.
- Do not install or use a damaged appliance.
- Follow the installation instructions supplied with the appliance.
- Always take care when moving the appliance as it is heavy. Always use safety gloves and enclosed footwear.
- Do not pull the appliance by the handle.
- Install the appliance in a safe and suitable place that meets installation requirements.
- Keep the minimum distance from other appliances and units.
- Before mounting the appliance, check if the oven door opens without restraint.
- The appliance is equipped with an electric cooling system. It must be operated with the electric power supply.

Cabinet minimum height (Cabinet under the worktop minimum height)	590 (600) mm
---	--------------

Cabinet width	560 mm
Cabinet depth	550 (550) mm
Height of the front of the appliance	594 mm
Height of the back of the appliance	576 mm
Width of the front of the ap- pliance	595 mm
Width of the back of the appliance	559 mm
Depth of the appliance	569 mm
Built in depth of the appli- ance	548 mm
Depth with open door	1022 mm
Ventilation opening mini- mum size. Opening placed on the bottom rear side	560x20 mm
Mains supply cable length. Cable is placed in the right corner of the back side	1500 mm
Mounting screws	4x25 mm

2.2 Electrical connection



WARNING!

Risk of fire and electric shock.

- All electrical connections should be made by a qualified electrician.
- The appliance must be earthed.
- Make sure that the parameters on the rating plate are compatible with the electrical ratings of the mains power supply.
- Always use a correctly installed shockproof socket.
- Do not use multi-plug adapters and extension cables.
- Make sure not to cause damage to the mains plug and to the mains cable. Should the mains cable need to be replaced, this must be carried out by our Authorised Service Centre.
- Do not let mains cables touch or come near the appliance door or the niche below the appliance, especially when it operates or the door is hot.
- The shock protection of live and insulated parts must be fastened in such a way that it cannot be removed without tools.
- Connect the mains plug to the mains socket only at the end of the installation. Make sure that there is access to the mains plug after the installation.
- If the mains socket is loose, do not connect the mains plug.
- Do not pull the mains cable to disconnect the appliance. Always pull the mains plug.
- Use only correct isolation devices: line protecting cut-outs, fuses (screw type fuses removed from the holder), earth leakage trips and contactors.
- The electrical installation must have an isolation device which lets you disconnect the appliance from the mains at all poles. The isolation device must have a contact opening width of minimum 3 mm.
- This appliance is supplied with a main plug and a main cable.

Cable types applicable for installation or replacement for Europe:

H07 RN-F, H05 RN-F, H05 RRF, H05 VV-F, H05 V2V2-F (T90), H05 BB-F

For the section of the cable refer to the total power on the rating plate. You can also refer to the table:

Total power (W)	Section of the cable (mm ²)
maximum 1380	3 x 0.75
maximum 2300	3 x 1
maximum 3680	3 x 1.5

The earth cord (green / yellow cable) must be 2 cm longer than phase and neutral cables (blue and brown cables).

2.3 Use



WARNING!

Risk of injury, burns and electric shock or explosion.

- This appliance is for household use only.
- Do not change the specification of this appliance.
- Make sure that the ventilation openings are not blocked.
- Do not let the appliance stay unattended during operation.
- Deactivate the appliance after each use.
- Be careful when you open the appliance door while the appliance is in operation. Hot air can release.
- Do not operate the appliance with wet hands or when it has contact with water.
- Do not apply pressure on the open door.
- Do not use the appliance as a work surface or as a storage surface.
- Open the appliance door carefully. The use of ingredients with alcohol can cause a mixture of alcohol and air.
- Do not let sparks or open flames to come in contact with the appliance when you open the door.
- Do not put flammable products or items that are wet with flammable products in, near or on the appliance.



WARNING!

Risk of damage to the appliance.

- To prevent damage or discoloration to the enamel:
 - do not put ovenware or other objects in the appliance directly on the bottom.

- do not put aluminium foil directly on the bottom of cavity of the appliance.
- do not put water directly into the hot appliance.
- do not keep moist dishes and food in the appliance after you finish the cooking.
- be careful when you remove or install the accessories.
- Discoloration of the enamel or stainless steel has no effect on the performance of the appliance.
- Use a deep pan for moist cakes. Fruit juices cause stains that can be permanent.
- This appliance is for cooking purposes only. It must not be used for other purposes, for example room heating.
- Always cook with the oven door closed.
- If the appliance is installed behind a furniture panel (e.g. a door) make sure the door is never closed when the appliance operates. Heat and moisture can build up behind a closed furniture panel and cause subsequent damage to the appliance, the housing unit or the floor. Do not close the furniture panel until the appliance has cooled down completely after use.

2.4 Care and cleaning



WARNING!

Risk of injury, fire, or damage to the appliance.

- Before maintenance, deactivate the appliance and disconnect the mains plug from the mains socket.
- Make sure the appliance is cold. There is the risk that the glass panels can break.
- Replace immediately the door glass panels when they are damaged. Contact the Authorised Service Centre.
- Be careful when you remove the door from the appliance. The door is heavy!
- Clean regularly the appliance to prevent the deterioration of the surface material.

- Clean the appliance with a moist soft cloth. Use only neutral detergents. Do not use abrasive products, abrasive cleaning pads, solvents or metal objects.
- If you use an oven spray, follow the safety instructions on its packaging.

2.5 Internal lighting



WARNING!

Risk of electric shock.

- Concerning the lamp(s) inside this product and spare part lamps sold separately: These lamps are intended to withstand extreme physical conditions in household appliances, such as temperature, vibration, humidity, or are intended to signal information about the operational status of the appliance. They are not intended to be used in other applications and are not suitable for household room illumination.
- Use only lamps with the same specifications.

2.6 Service

- To repair the appliance contact the Authorised Service Centre.
- Use original spare parts only.

2.7 Disposal



WARNING!

Risk of injury or suffocation.

- Disconnect the appliance from the mains supply.
- Cut off the mains electrical cable close to the appliance and dispose of it.
- Remove the door catch to prevent children or pets from becoming trapped in the appliance.

3. INSTALLATION



WARNING!

Refer to Safety chapters.

3.1 Building in



www.youtube.com/electrolux
www.youtube.com/aeg

How to install your AEG/Electrolux
Oven - Column installation

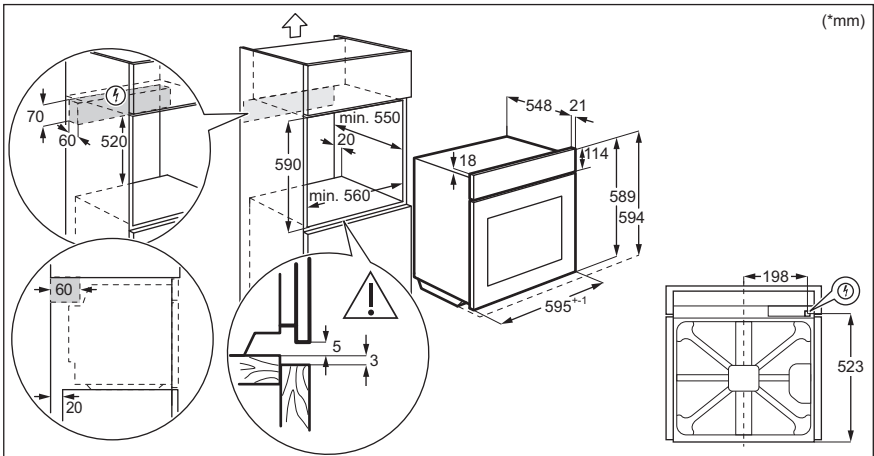
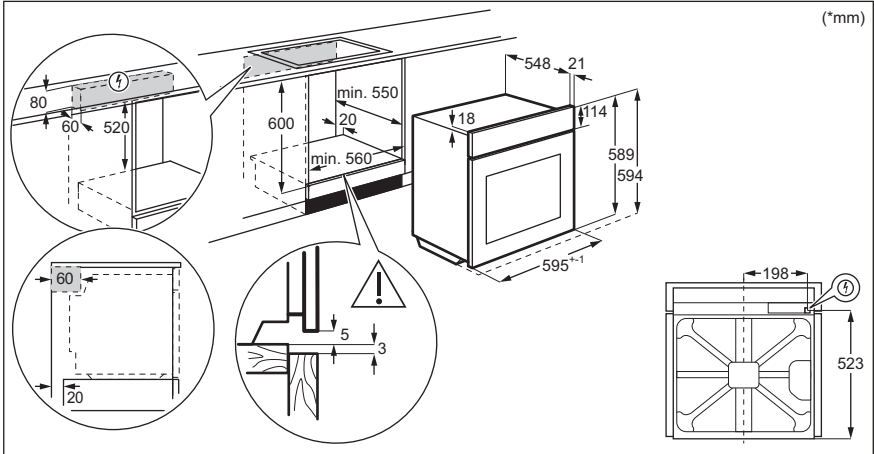

3.2 Securing the oven to the cabinet

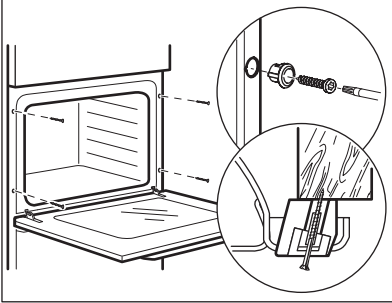

4. PRODUCT DESCRIPTION

4.1 General overview

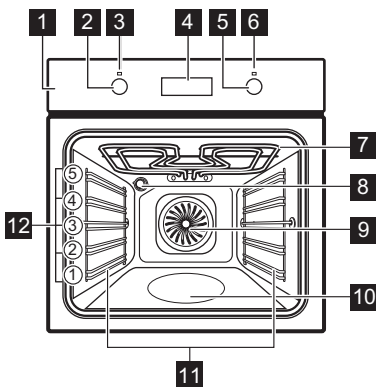

- 1 Control panel
- 2 Knob for the heating functions
- 3 Power lamp / symbol
- 4 Display
- 5 Control knob (for the temperature)
- 6 Temperature indicator / symbol
- 7 Heating element
- 8 Lamp
- 9 Fan
- 10 Cavity embossment - Aqua cleaning container
- 11 Shelf support, removable
- 12 Shelf positions

4.2 Accessories

- **Wire shelf**
For cookware, cake tins, roasts.
- **Combi pan**
For cakes and biscuits. To bake and roast or as a pan to collect fat.

- **Telescopic runners**
With the telescopic runners you can put in and remove the shelves more easily.

5. CONTROL PANEL

5.1 Retractable knobs

To use the appliance press the knob. The knob comes out.

5.2 Sensor fields / Buttons

—	To set the time.
	To set a clock function.
+	To set the time.

5.3 Display

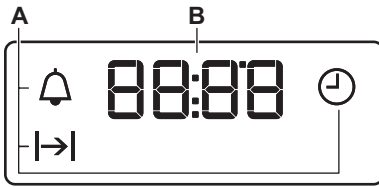

- A. Clock functions
- B. Timer

6. BEFORE FIRST USE



WARNING!

Refer to Safety chapters.

6.1 Before first use

The oven can emit an odour and smoke during preheating. Make sure that the room is ventilated.



Step 1

Set the clock

1.  - press to set the time. After approximately 5 sec., the flashing stops and the display shows the time.



Step 2



Clean the oven

1. Remove all accessories and removable shelf supports from the oven.
2. Clean the oven and the accessories with a soft cloth, warm water and a mild detergent.



Step 3

Preheat the empty oven

1. Set the maximum temperature for the function: . Time: 1 h.
2. Set the maximum temperature for the function: . Time: 15 min.
3. Set the maximum temperature for the function: . Time: 15 min.

Turn off the oven and wait until it is cold. Place the accessories and the removable shelf supports in the oven.

7. DAILY USE



WARNING!

Refer to Safety chapters.





7.1 How to set: Heating function





Step 1 Turn the knob for the heating functions to select a heating function.

Step 2 Turn the control knob to select the temperature.

Step 3 When the cooking ends, turn the knobs to the off position to turn off the oven.

7.2 Heating functions

Heating function	Application
 Off position	The oven is off.
 Light	To turn on the lamp.
 Moist Fan Baking	This function is designed to save energy during cooking. When you use this function, the temperature in the cavity may differ from the set temperature. The residual heat is used. The heating power may be reduced. For more information refer to "Daily Use" chapter, Notes on: Moist Fan Baking.
 True Fan Cooking	To bake on up to three shelf positions at the same time and to dry food. Set the temperature 20 - 40 °C lower than for Conventional Cooking.
 Bottom Heat	To bake cakes with crispy bottom and to preserve food.

Heating function	Application
 Turbo Grilling	To roast large meat joints or poultry with bones on one shelf position. To make gratins and to brown.
 Pizza Function	To bake pizza. To make intensive browning and a crispy bottom.
 Defrost	To defrost food (vegetables and fruit). The defrosting time depends on the amount and size of the frozen food.
 Fast Grilling	To grill thin pieces of food in large quantities and to toast bread.
 Conventional Cooking / Aqua Clean	To bake and roast food on one shelf position. Refer to "Care and cleaning" chapter for more information about: Aqua Clean.

7.3 Notes on: Moist Fan Baking

This function was used to comply with the energy efficiency class and ecodesign requirements according to EU 65/2014 and EU 66/2014. Tests according to EN 60350-1.



The oven door should be closed during cooking so that the function is not interrupted and the oven operates with the highest energy efficiency possible.

When you use this function the lamp automatically turns off.

For the cooking instructions refer to "Hints and tips" chapter, Moist Fan Baking. For general energy saving recommendations refer to "Energy Efficiency" chapter, Energy Saving.

8. CLOCK FUNCTIONS

8.1 Clock functions



Clock function	Application
 Time of Day	To set, change or check the time of day.
 Duration	To set how long the oven works.
 Minute Minder	To set a countdown. This function has no effect on the operation of the oven. You can set this function at any time, also when the oven is off.



8.2 How to set: Clock functions

How to change: Time of Day

 - flashes when you connect the oven to the electrical supply, when there was a power cut or when the timer is not set.

Step 1  - press repeatedly.  - starts to flash.





Step 2  ,  - press to set the time.
After approximately 5 sec., the flashing stops and the display shows the time.

 - press repeatedly to change the time of day.  - starts to flash.

How to set: Duration

Step 1 Set an oven function and the temperature.



Step 2  - press repeatedly.  - starts to flash.



Step 3  ,  - press to set the duration.
The display shows: 
 - flashes when the set time ends. The signal sounds and the oven turns off.

Step 4 Press any button to stop the signal.

Step 5 Turn the knobs to the off position.

How to set: Minute Minder

Step 1  - press repeatedly.  - starts to flash.

Step 2  ,  - press to set the time.
The function starts automatically after 5 sec.
When the set time ends, the signal sounds.

Step 3 Press any button to stop the signal.

How to set: Minute Minder

Step 4 Turn the knobs to the off position.

How to cancel: Clock functions

Step 1  - press repeatedly until the clock function symbol starts to flash.

Step 2 Press and hold: .
The clock function turns off after few seconds.

9. USING THE ACCESSORIES



WARNING!

Refer to Safety chapters.

9.1 Inserting accessories

A small indentation at the top increases safety. The indentations are also anti-tip

Wire shelf:

Push the shelf between the guide bars of the shelf support and make sure that the feet point down.

devices. The high rim around the shelf prevents cookware from slipping of the shelf.

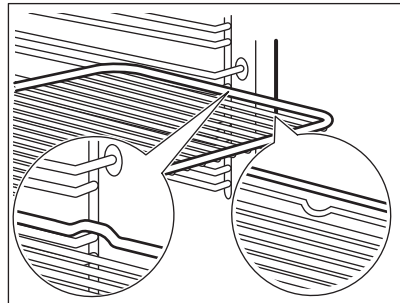

Deep pan:

Push the tray between the guide bars of the shelf support.

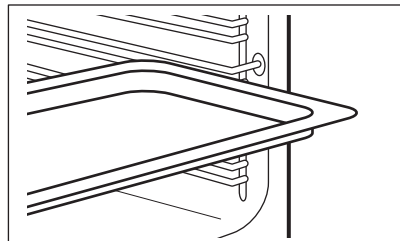

Wire shelf, Deep pan:

Push the tray between the guide bars of the shelf support and the wire shelf on the guide bars above.

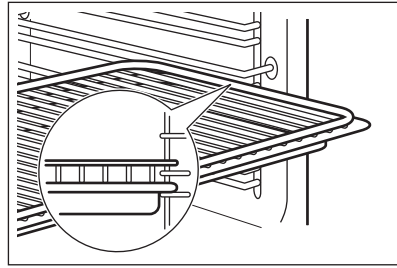
**9.2 Using telescopic runners**

Do not oil the telescopic runners.

Make sure you push back the telescopic runners fully in the oven before you close the oven door.

Step 1 Pull out the right and left hand telescopic runners.

Step 2 Put the wire shelf on the telescopic runners and carefully push them into the oven.

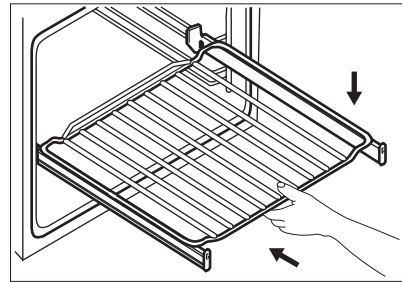
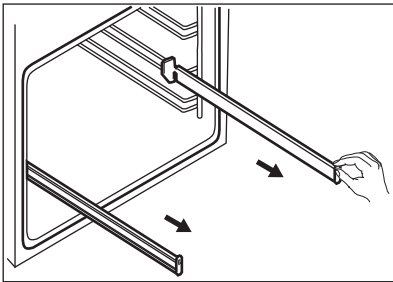
**10. ADDITIONAL FUNCTIONS****10.1 Cooling fan**

When the oven operates, the cooling fan turns on automatically to keep the surfaces of the oven cool. If you turn off the oven, the cooling fan can continue to operate until the oven cools down.

10.2 Safety thermostat

Incorrect operation of the oven or defective components can cause dangerous overheating. To prevent this, the oven has a safety thermostat which interrupts the power supply. The oven turns on again automatically when the temperature drops.

11. HINTS AND TIPS

Refer to Safety chapters.

11.1 Cooking recommendations

The oven has five shelf positions.

Count the shelf positions from the bottom of the oven floor.

Your oven may bake or roast differently to the oven you had before. The below tables provide you with the standard settings for temperature, cooking time and shelf position.

If you cannot find the settings for a special recipe, look for the similar one.

The oven has a special system which circulates the air and constantly recycles the steam. With this system you can cook in a steamy environment and keep the food soft inside and crusty outside. It decreases the cooking time and energy consumption.

Baking cakes

Do not open the oven door before 3/4 of the set cooking time is up.

If you use two baking trays at the same time, keep one empty level between them.

Cooking meat and fish

Use a deep pan for very fatty food to prevent the oven from stains that can be permanent.

Leave the meat for approximately 15 minutes before carving so that the juice does not seep out.







To prevent too much smoke in the oven during roasting, add some water into the deep pan. To prevent the smoke condensation, add water each time after it dries up.







Cooking times

Cooking times depend on the type of food, its consistency, and volume.







Initially, monitor the performance when you cook. Find the best settings (heat setting, cooking time, etc.) for your cookware, recipes and quantities when you use this appliance.

11.2 Baking and roasting

 CAKES	Conventional Cooking		True Fan Cooking		 (min)	
	 (°C)		 (°C)			
Whisked recipes	170	2	160	3 (2 and 4)	45 - 60	Cake mould
Shortbread dough	170	2	160	3 (2 and 4)	20 - 30	Cake mould
Buttermilk cheese-cake	170	1	165	2	60 - 80	Cake mould, Ø 26 cm
Strudel	175	3	150	2	60 - 80	Baking tray
Jam tart	170	2	165	2	30 - 40	Cake mould, Ø 26 cm
Christmas cake, preheat the empty oven	160	2	150	2	90 - 120	Cake mould, Ø 20 cm
Plum cake, pre-heat the empty oven	175	1	160	2	50 - 60	Bread tin
Muffins	170	3	140 - 150	3	20 - 30	Baking tray
Muffins, two levels	-	-	140 - 150	2 and 4	25 - 35	Baking tray
Muffins, three levels	-	-	140 - 150	1, 3 and 5	30 - 45	Baking tray
Biscuits	140	3	140 - 150	3	30 - 35	Baking tray
Biscuits, two levels	-	-	140 - 150	2 and 4	35 - 40	Baking tray
Biscuits, three levels	-	-	140 - 150	1, 3 and 5	35 - 45	Baking tray







 CAKES	Conventional Cooking		True Fan Cooking		 (min)	
	 (°C)		 (°C)			
Meringues	120	3	120	3	80 - 100	Baking tray
Meringues, two levels, preheat the empty oven	-	-	120	2 and 4	80 - 100	Baking tray
Buns, preheat the empty oven	190	3	190	3	12 - 20	Baking tray
Eclairs	190	3	170	3	25 - 35	Baking tray
Eclairs, two levels	-	-	170	2 and 4	35 - 45	Baking tray
Plate tarts	180	2	170	2	45 - 70	Cake mould, Ø 20 cm
Rich fruit cake	160	1	150	2	110 - 120	Cake mould, Ø 24 cm







Preheat the empty oven.

 BREAD AND PIZZA	Conventional Cooking		True Fan Cooking		 (min)	
	 (°C)		 (°C)			
White bread, 1 - 2 pieces, 0.5 kg each	190	1	190	1	60 - 70	-
Rye bread, preheating is not needed	190	1	180	1	30 - 45	Bread tin
Bread rolls, 6 - 8 rolls	190	2	180	2 (2 and 4)	25 - 40	Baking tray
Pizza	230 - 250	1	230 - 250	1	10 - 20	Enamelled tray
Scones	200	3	190	3	10 - 20	Baking tray

Preheat the empty oven.







Use the cake mould.







 FLANS	Conventional Cooking		True Fan Cooking		 (min)
	 (°C)		 (°C)		
Pasta flan, preheating is not needed	200	2	180	2	40 - 50







 FLANS	Conventional Cooking		True Fan Cooking		 (min)
	 (°C)		 (°C)		
Vegetable flan, preheating is not needed	200	2	175	2	45 - 60
Quiches	180	1	180	1	50 - 60
Lasagne	180 - 190	2	180 - 190	2	25 - 40
Cannelloni	180 - 190	2	180 - 190	2	25 - 40

Use the second shelf position.





Use the wire shelf.

 MEAT	Conventional Cooking		True Fan Cooking		 (min)
	 (°C)		 (°C)		
Beef	200		190		50 - 70
Pork	180		180		90 - 120
Veal	190		175		90 - 120
English roast beef, rare	210		200		50 - 60
English roast beef, medium	210		200		60 - 70
English roast beef, well done	210		200		70 - 75

 MEAT	Conventional Cooking		True Fan Cooking		 (min)
	 (°C)		 (°C)		
Pork shoulder, with rind	180	2	170	2	120 - 150
Pork shin, 2 pieces	180	2	160	2	100 - 120
Leg of lamb	190	2	175	2	110 - 130
Whole chicken	220	2	200	2	70 - 85
Whole turkey	180	2	160	2	210 - 240
Whole duck	175	2	220	2	120 - 150
Whole goose	175	2	160	1	150 - 200
Rabbit, cut in pieces	190	2	175	2	60 - 80
Hare, cut in pieces	190	2	175	2	150 - 200

 MEAT	Conventional Cooking		True Fan Cooking		 (min)
	 (°C)		 (°C)		
Whole pheasant	190	2	175	2	90 - 120

Use the second shelf position.





 FISH	Conventional Cooking		True Fan Cooking		 (min)
	 (°C)		 (°C)		
Trout / Sea bream, 3 - 4 fish	190		175		40 - 55
Tuna / Salmon, 4 - 6 fillets	190		175		35 - 60

11.3 Grill

Preheat the empty oven.

Use the fourth shelf position.

Grill with the maximum temperature setting.



 GRILL	 (kg)	 (min)	 (min)
		1st side	2nd side
Fillet steaks, 4 pieces	0.8	12 - 15	12 - 14
Beef steak, 4 pieces	0.6	10 - 12	6 - 8
Sausages, 8	-	12 - 15	10 - 12
Pork chops, 4 pieces	0.6	12 - 16	12 - 14
Chicken, half, 2	1	30 - 35	25 - 30
Kebabs, 4	-	10 - 15	10 - 12
Chicken breast, 4 pieces	0.4	12 - 15	12 - 14
Burgers, 6	0.6	20 - 30	-
Fish fillet, 4 pieces	0.4	12 - 14	10 - 12
Toasted sandwiches, 4 - 6	-	5 - 7	-
Toast, 4 - 6	-	2 - 4	2 - 3



11.4 Turbo Grilling



Preheat the empty oven.



Use the first or the second shelf position.



To calculate the roasting time multiple the time given in the table below by the centimetres of thickness of the fillet.



 BEEF	 (°C)	 (min)
Roast beef or fillet, rare	190 - 200	5 - 6
Roast beef or fillet, medium	180 - 190	6 - 8
Roast beef or fillet, well done	170 - 180	8 - 10



 PORK	 (°C)	 (min)
Shoulder / Neck / Ham joint, 1 - 1.5 kg	160 - 180	90 - 120
Chops / Spare rib, 1 - 1.5 kg	170 - 180	60 - 90
Meatloaf, 0.75 - 1 kg	160 - 170	50 - 60
Pork knuckle, pre-cooked, 0.75 - 1 kg	150 - 170	90 - 120

 VEAL	 (°C)	 (min)
Roast veal, 1 kg	160 - 180	90 - 120
Veal knuckle, 1.5 - 2 kg	160 - 180	120 - 150





 LAMB	 (°C)	 (min)
Lamb leg / Roast lamb, 1 - 1.5 kg	150 - 170	100 - 120





 LAMB	 (°C)	 (min)
Lamb saddle, 1 - 1.5 kg	160 - 180	40 - 60

 POULTRY	 (°C)	 (min)
Poultry, portions, 0.2 - 0.25 kg each	200 - 220	30 - 50
Chicken, half, 0.4 - 0.5 kg each	190 - 210	35 - 50
Chicken, poulard, 1 - 1.5 kg	190 - 210	50 - 70
Duck, 1.5 - 2 kg	180 - 200	80 - 100
Goose, 3.5 - 5 kg	160 - 180	120 - 180
Turkey, 2.5 - 3.5 kg	160 - 180	120 - 150
Turkey, 4 - 6 kg	140 - 160	150 - 240

 FISH (STEAMED)	 (°C)	 (min)
Whole fish, 1 - 1.5 kg	210 - 220	40 - 60

11.5 Defrost

	 (kg)	 Defrosting time (min)	 Further defrosting time (min)	
Chicken	1	100 - 140	20 - 30	Place chicken on an up-turned saucer placed on a large plate. Turn halfway through.

	 (kg)	 Defrosting time (min)	 Further defrosting time (min)	
Meat	1	100 - 140	20 - 30	Turn halfway through.
	0.5	90 - 120		
Cream	2 x 0.2	80 - 100	10 - 15	Cream can also be whipped when still slightly frozen in places.
Trout	0.15	25 - 35	10 - 15	-
Strawberries	0.3	30 - 40	10 - 20	-
Butter	0.25	30 - 40	10 - 15	-
Gateau	1.4	60	60	-



11.6 Dehydrating - True Fan Cooking



Cover trays with grease proof paper or baking parchment.

For a better result, stop the oven halfway through the drying time, open the door and let it cool down for one night to complete the drying.



For 1 tray use the third shelf position.

For 2 trays use the first and fourth shelf position.

 VEGETABLES	 (°C)	 (h)
Beans	60 - 70	6 - 8
Peppers	60 - 70	5 - 6

 VEGETABLES	 (°C)	 (h)
Vegetables for soup	60 - 70	5 - 6
Mushrooms	50 - 60	6 - 8
Herbs	40 - 50	2 - 3

Set the temperature to 60 - 70 °C.

 FRUIT	 (h)
Plums	8 - 10
Apricots	8 - 10
Apple slices	6 - 8
Pears	6 - 9

11.7 Moist Fan Baking - recommended accessories

Use the dark and non-reflective tins and containers. They have better heat absorption than the light colour and reflective dishes.



Pizza pan



Baking dish



Ramekins

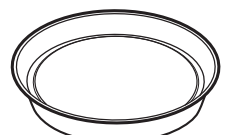

Flan base tin

Dark, non-reflective
28 cm diameter





Dark, non-reflective
26 cm diameter

Ceramic
8 cm diameter, 5
cm height

Dark, non-reflective
28 cm diameter







11.8 Moist Fan Baking

For the best results follow suggestions listed in the table below.

		 (°C)		 (min)
Sweet rolls, 12 pieces	baking tray or dripping pan	175	3	40 - 50
Rolls, 9 pieces	baking tray or dripping pan	180	2	35 - 45
Pizza, frozen, 0.35 kg	wire shelf	180	2	45 - 55
Swiss roll	baking tray or dripping pan	170	2	30 - 40
Brownie	baking tray or dripping pan	170	2	45 - 50
Soufflé, 6 pieces	ceramic ramekins on wire shelf	190	3	45 - 55
Sponge flan base	flan base tin on wire shelf	180	2	35 - 45
Victoria sandwich	baking dish on wire shelf	170	2	35 - 50
Poached fish, 0.3 kg	baking tray or dripping pan	180	2	35 - 45
Whole fish, 0.2 kg	baking tray or dripping pan	180	3	25 - 35
Fish fillet, 0.3 kg	pizza pan on wire shelf	170	3	30 - 40
Poached meat, 0.25 kg	baking tray or dripping pan	180	3	35 - 45
Shashlik, 0.5 kg	baking tray or dripping pan	180	3	40 - 50
Cookies, 16 pieces	baking tray or dripping pan	150	2	30 - 45
Macaroons, 20 pieces	baking tray or dripping pan	180	2	45 - 55
Muffins, 12 pieces	baking tray or dripping pan	170	2	30 - 40
Savory pastry, 16 pieces	baking tray or dripping pan	170	2	35 - 45
Short crust biscuits, 20 pieces	baking tray or dripping pan	150	2	40 - 50
Tartlets, 8 pieces	baking tray or dripping pan	170	2	30 - 40
Vegetables, poached, 0.4 kg	baking tray or dripping pan	180	2	35 - 45
Vegetarian omelette	pizza pan on wire shelf	180	3	35 - 45
Mediterranean vegetables, 0.7 kg	baking tray or dripping pan	180	4	35 - 45

11.9 Information for test institutes

Tests according to IEC 60350-1.

				 (°C)	 (min)	
Small cakes, 20 per tray	Conventional Cooking	Baking tray	3	170	20 - 30	-
Small cakes, 20 per tray	True Fan Cooking	Baking tray	3	150 - 160	20 - 35	-
Small cakes, 20 per tray	True Fan Cooking	Baking tray	2 and 4	150 - 160	20 - 35	-
Apple pie, 2 tins Ø20 cm	Conventional Cooking	Wire shelf	2	180	70 - 90	-
Apple pie, 2 tins Ø20 cm	True Fan Cooking	Wire shelf	2	160	70 - 90	-
Sponge cake, cake mould Ø26 cm	Conventional Cooking	Wire shelf	2	170	40 - 50	Preheat the oven for 10 minutes.
Sponge cake, cake mould Ø26 cm	True Fan Cooking	Wire shelf	2	160	40 - 50	Preheat the oven for 10 minutes.
Sponge cake, cake mould Ø26 cm	True Fan Cooking	Wire shelf	2 and 4	160	40 - 60	Preheat the oven for 10 minutes.
Short bread	True Fan Cooking	Baking tray	3	140 - 150	20 - 40	-
Short bread	True Fan Cooking	Baking tray	2 and 4	140 - 150	25 - 45	-
Short bread	Conventional Cooking	Baking tray	3	140 - 150	25 - 45	-
Toast, 4 - 6 pieces	Grill	Wire shelf	4	max.	2 - 3 minutes first side; 2 - 3 minutes second side	Preheat the oven for 3 minutes.
Beef burger, 6 pieces, 0.6 kg	Grill	Wire shelf and dripping pan	4	max.	20 - 30	Put the wire shelf on the fourth level and the dripping pan on the third level of the oven. Turn the food halfway through the cooking time. Preheat the oven for 3 minutes.

12. CARE AND CLEANING



WARNING!

Refer to Safety chapters.

12.1 Notes on cleaning



Cleaning Agents

Clean the front of the oven with a soft cloth with warm water and a mild detergent. Clean and check the door gasket around the frame of the cavity.

Use a cleaning solution to clean metal surfaces.

Clean stains with a mild detergent.



Everyday Use

Clean the cavity after each use. Fat accumulation or other residue may cause fire.

Moisture can condense in the oven or on the door glass panels. To decrease the condensation, let the oven work for 10 minutes before cooking. Do not store the food in the oven for longer than 20 minutes. Dry the cavity with a soft cloth after each use.



Accessories

Clean all accessories after each use and let them dry. Use a soft cloth with warm water and a mild detergent. Do not clean the accessories in a dishwasher.

Do not clean the non-stick accessories using abrasive cleaner or sharp-edged objects.

12.2 How to remove: Shelf supports

Remove the shelf supports to clean the oven.

Step 1 Turn off the oven and wait until it is cold.

Step 2 Pull the front of the shelf support away from the side wall.

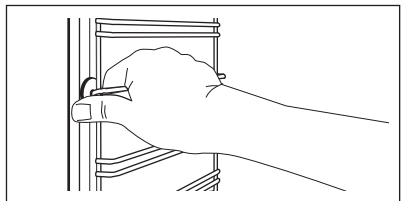

Step 3 Pull the rear end of the shelf support away from the side wall and remove it.

Step 4 Install the shelf supports in the opposite sequence. The retaining pins on the telescopic runners must point to the front.

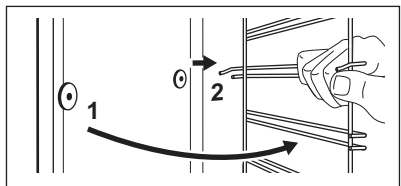

12.3 How to use: Aqua Clean

This cleaning procedure uses humidity to remove remaining fat and food particles from the oven.

Step 1 Pour water into the cavity embossment: 300 ml.

Step 2 Set the function: 

Step 3 Set the temperature to 90 °C.

Step 4 Let the oven work for 30 min.

Step 5 Turn off the oven.

Step 6 Wait until the oven is cold. Dry the cavity with a soft cloth.

12.4 How to remove and install: Door

The oven door has two glass panels. You can remove the oven door and the internal glass panel to clean it. Read the whole "Removing and installing door" instruction before you remove the glass panels.



CAUTION!

Do not use the oven without the glass panels.

Step 1 Open the door fully and hold both hinges.

Step 2 Lift and turn the levers fully on both hinges.

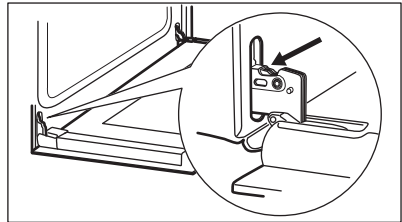

Step 3 Close the oven door halfway to the first opening position. Then lift and pull forward and remove the door from its seat.

Step 4 Put the door on a soft cloth on a stable surface.

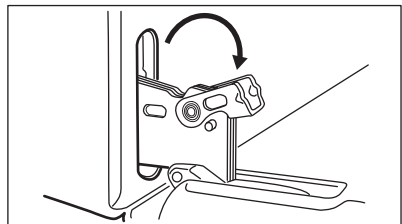

Step 5 Hold the door trim (B) on the top edge of the door at the two sides and push inwards to release the clip seal.

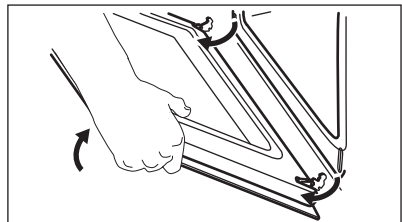

Step 6 Pull the door trim to the front to remove it.

Step 7 Hold the door glass panel by its top edge and carefully pull it out. Make sure the glass slides out of the supports completely.

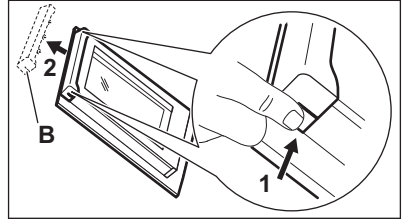

Step 8 Clean the glass panels with water and soap. Dry the glass panels carefully. Do not clean the glass panels in the dishwasher.

Step 9 After cleaning, install the glass panel and the oven door.

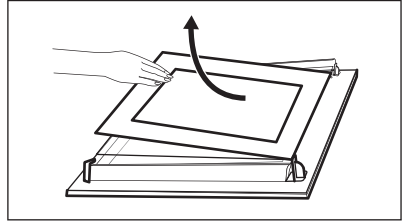

The screen-printing zone must face the inner side of the door. Make sure that after the installation the surface of the glass panel frame on the screen-printing zones is not rough when you touch it. When installed correctly the door trim clicks. Make sure that you install the internal glass panel in the seats correctly.

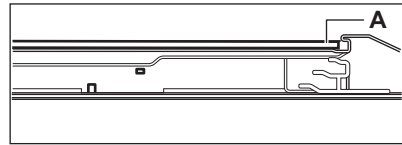

12.5 How to replace: Lamp



WARNING!
Risk of electric shock.
The lamp can be hot.

Always hold the halogen lamp with a cloth to prevent grease residue from burning on the lamp.

Before you replace the lamp:

Step 1	Step 2	Step 3
Turn off the oven. Wait until the oven is cold.	Disconnect the oven from the mains.	Put a cloth on the bottom of the cavity.

Back lamp

Step 1 Turn the glass cover to remove it.

Step 2 Clean the glass cover.

Step 3 Replace the lamp with a suitable 300 °C heat-resistant lamp.

Step 4 Install the glass cover.

13. TROUBLESHOOTING



WARNING!

Refer to Safety chapters.

13.1 What to do if...

In any cases not included in this table please contact with an Authorised Service Centre.

Problem	Check if...
The oven does not heat up.	The fuse is blown.
The door gasket is damaged.	Do not use the oven. Contact an Authorised Service Centre.

Problem	Check if...
The display shows "12.00".	There was a power cut. Set the time of day.
The lamp does not work.	The lamp is burnt out.

13.2 Service data

If you cannot find a solution to the problem yourself, contact your dealer or an Authorised Service Centre.

The necessary data for the service centre is on the rating plate. The rating plate is on the front frame of the oven cavity. Do not remove the rating plate from the oven cavity.

We recommend that you write the data here:

Model (MOD.)
Product number (PNC)
Serial number (S.N.)

14. ENERGY EFFICIENCY

14.1 Product Information and Product Information Sheet*

Supplier's name	Electrolux	
Model identification	EOF3H54X 949496302 KOF5H54X 949496300	
Energy Efficiency Index	81.2	
Energy efficiency class	A+	
Energy consumption with a standard load, conventional mode	0.93 kWh/cycle	
Energy consumption with a standard load, fan-forced mode	0.69 kWh/cycle	
Number of cavities	1	
Heat source	Electricity	
Volume	72 l	
Type of oven	Built-In Oven	
Mass	EOF3H54X	27.8 kg
	KOF5H54X	27.5 kg

* For European Union according to EU Regulations 65/2014 and 66/2014.
For Republic of Belarus according to STB 2478-2017, Appendix G; STB 2477-2017, Annexes A and B.
For Ukraine according to 568/32020.

Energy efficiency class is not applicable for Russia.

EN 60350-1 - Household electric cooking appliances - Part 1: Ranges, ovens, steam ovens and grills - Methods for measuring performance.

14.2 Energy saving



The oven has features which help you save energy during everyday cooking.

Make sure that the oven door is closed when the oven operates. Do not open the oven door too often during cooking. Keep the door gasket clean and make sure it is well fixed in its position.

Use metal cookware to improve energy saving.

When possible, do not preheat the oven before cooking.

Keep breaks between baking as short as possible when you prepare a few dishes at one time.

Cooking with fan

When possible, use the cooking functions with fan to save energy.

Residual heat

When the cooking duration is longer than 30 min, reduce the oven temperature to minimum 3 - 10 min before the end of cooking. The residual heat inside the oven will continue to cook.

Use the residual heat to warm up other dishes.

Keep food warm

Choose the lowest possible temperature setting to use residual heat and keep a meal warm.

Moist Fan Baking

Function designed to save energy during cooking.

When you use this function the lamp is off.

15. ENVIRONMENTAL CONCERNS

Recycle materials with the symbol . Put the packaging in relevant containers to recycle it. Help protect the environment and human health by recycling waste of electrical and electronic appliances. Do not dispose of

appliances marked with the symbol  with the household waste. Return the product to your local recycling facility or contact your municipal office.

ESTAMOS A PENSAR EM SI

Obrigado por ter adquirido um aparelho Electrolux. Escolheu um produto que traz com ele décadas de experiência profissional e inovação. Engenhoso e elegante, foi concebido a pensar em si. Assim, quando o utilizar, terá a tranquilidade de saber que obterá sempre ótimos resultados.

Bem-vindo(a) à Electrolux.

Visite o nosso website para:



Resolver problemas e obter conselhos de utilização, catálogos e informações sobre assistência e reparações:

www.electrolux.com/support



Registar o seu produto para beneficiar de um serviço melhor:

www.registerelectrolux.com



Adquirir acessórios, consumíveis e peças de substituição originais para o seu aparelho:

www.electrolux.com/shop

APOIO AO CLIENTE E ASSISTÊNCIA

Utilize sempre peças de substituição originais.

Quando contactar o nosso Centro de Assistência Técnica Autorizado, certifique-se de que tem os seguintes dados disponíveis: Modelo, PNC, Número de Série.

A informação pode ser encontrada na placa de características.

 Aviso / Cuidado - Informações de segurança

 Informações gerais e sugestões

 Informações ambientais

Sujeito a alterações sem aviso prévio.

ÍNDICE

1. INFORMAÇÕES DE SEGURANÇA.....	28
2. INSTRUÇÕES DE SEGURANÇA.....	29
3. INSTALAÇÃO.....	32
4. DESCRIÇÃO DO PRODUTO.....	34
5. PAINEL DE COMANDOS.....	34
6. ANTES DA PRIMEIRA UTILIZAÇÃO.....	35
7. UTILIZAÇÃO DIÁRIA.....	35
8. FUNÇÕES DE RELÓGIO.....	37
9. UTILIZAR OS ACESSÓRIOS.....	38
10. FUNÇÕES ADICIONAIS.....	39
11. SUGESTÕES E DICAS.....	40
12. MANUTENÇÃO E LIMPEZA.....	49
13. RESOLUÇÃO DE PROBLEMAS.....	52
14. EFICIÊNCIA ENERGÉTICA.....	53

1. ⚠️ INFORMAÇÕES DE SEGURANÇA

Leia atentamente as instruções fornecidas antes de instalar e utilizar o aparelho. O fabricante não é responsável por quaisquer ferimentos ou danos resultantes de instalação ou utilização incorretas. Guarde sempre as instruções em local seguro e acessível para consultar no futuro.

1.1 Segurança de crianças e pessoas vulneráveis

- Este aparelho pode ser utilizado por crianças de 8 ou mais anos de idade e por pessoas com capacidades físicas, sensoriais ou mentais reduzidas ou com pouca experiência e conhecimento se tiverem recebido supervisão ou instruções relativas à utilização do aparelho de forma segura e compreenderem os perigos envolvidos. É necessário manter as crianças com menos de 8 anos de idade e pessoas com incapacidades muito extensas e complexas afastadas do aparelho, a menos que constantemente vigiadas.
- Não permita que crianças brinquem com o aparelho.
- Mantenha todos os materiais de embalagem fora do alcance das crianças e elimine-os de forma apropriada.
- AVISO: Mantenha as crianças e os animais domésticos afastados do aparelho quando ele estiver a funcionar ou a arrefecer. As partes acessíveis ficam quentes durante a utilização.
- Se o aparelho tiver um dispositivo de segurança para crianças, recomendamos que o active.
- A limpeza e a manutenção básica do aparelho não devem ser efectuadas por crianças sem supervisão.

1.2 Segurança geral

- Apenas uma pessoa qualificada pode instalar este aparelho e substituir o cabo.
- AVISO: O aparelho e as partes acessíveis ficam quentes durante a utilização. Deve ter cuidado para evitar tocar nas resistências de aquecimento.

- Utilize sempre luvas de forno para retirar e colocar acessórios ou recipientes de ir ao forno.
- Antes de efetuar qualquer ação de manutenção, desligue o aparelho da corrente elétrica.
- **AVISO:** Certifique-se de que o aparelho está desligado antes de substituir a lâmpada, para evitar a possibilidade de choque elétrico.
- Não use o aparelho antes de instalá-lo na estrutura embutida.
- Não utilize uma máquina de limpar a vapor para limpar o aparelho.
- Não utilize agentes de limpeza abrasivos ou raspadores metálicos afiados para limpar a porta de vidro, porque podem riscar a superfície e causar a quebra do vidro.
- Se o cabo de alimentação elétrica estiver danificado, deve ser substituído pelo fabricante, por um Centro de Assistência Técnica Autorizado ou por uma pessoa igualmente qualificada, para evitar perigos elétricos.
- Para remover os apoios para prateleiras, puxe primeiro a parte da frente e depois a parte de trás do apoio para prateleiras para fora da parede lateral. Instale os apoios para prateleiras na sequência inversa.

2. INSTRUÇÕES DE SEGURANÇA

2.1 Instalação



AVISO!

A instalação deste aparelho tem de ser efetuada por uma pessoa qualificada.

- Retire a embalagem toda.
- Não instale nem utilize o aparelho se estiver danificado.
- Siga as instruções de instalação fornecidas com o aparelho.
- Tenha sempre cuidado quando deslocar o aparelho porque ele é pesado. Utilize sempre luvas de proteção e calçado fechado.
- Não puxe o aparelho pela pega.

- Instale o aparelho num local seguro e adequado que cumpra com os requisitos da instalação.
- Respeite as distâncias mínimas relativamente a outros aparelhos e unidades.
- Antes de montar o aparelho, verifique se a porta do forno abre sem limitações.
- O aparelho está equipado com um sistema de arrefecimento elétrico. É necessário que tenha alimentação elétrica.

Altura mínima do armário (altura mínima do armário debaixo do balcão)	590 (600) mm
---	--------------

Largura do armário	560 mm
--------------------	--------

Profundidade do armário	550 (550) mm
Altura da parte da frente do aparelho	594 mm
Altura da parte de trás do aparelho	576 mm
Largura da parte da frente do aparelho	595 mm
Largura da parte de trás do aparelho	559 mm
Profundidade do aparelho	569 mm
Profundidade de encastre do aparelho	548 mm
Profundidade com a porta aberta	1022 mm
Dimensão mínima da abertura de ventilação. Abertura localizada na parte inferior traseira	560x20 mm
Comprimento do cabo de alimentação eléctrica. O cabo sai pelo canto traseiro direito	1500 mm
Parafusos de montagem	4x25 mm

2.2 Ligação eléctrica



AVISO!

Risco de incêndio e choque eléctrico.

- Todas as ligações eléctricas devem ser efectuadas por um electricista qualificado.
- O aparelho tem de ficar ligado à terra.
- Certifique-se de que os parâmetros indicados na placa de características são compatíveis com as características da alimentação eléctrica.
- Utilize sempre uma tomada devidamente instalada e à prova de choques eléctricos.
- Não utilize adaptadores de tomadas duplas ou triplas, nem cabos de extensão.
- Certifique-se de que não danifica a ficha o cabo de alimentação eléctrica. Se for necessário substituir o cabo de alimentação, esta operação deve ser efectuada pelo nosso Centro de Assistência Técnica.
- Não permita que algum cabo eléctrico toque na porta do aparelho ou no nicho abaixo do aparelho, especialmente quando a porta estiver quente.

- As protecções contra choques eléctricos das peças isoladas e não isoladas devem estar fixas de modo a não poderem ser retiradas sem ferramentas.
- Ligue a ficha à tomada eléctrica apenas no final da instalação. Certifique-se de que a ficha fica acessível após a instalação.
- Se a tomada eléctrica estiver solta, não ligue a ficha.
- Não puxe o cabo de alimentação para desligar o aparelho. Puxe sempre a ficha.
- disjuntores de protecção, fusíveis (os fusíveis de rosca devem ser retirados do suporte), diferenciais e contactores.
- A instalação eléctrica deve possuir um dispositivo de isolamento que lhe permita desligar o aparelho da corrente eléctrica em todos os pólos. O dispositivo de isolamento deve ter uma abertura de contacto com uma largura mínima de 3 mm.
- Este aparelho é fornecido com ficha e com cabo de alimentação.

Tipos de cabos aplicáveis para instalação ou substituição para a Europa:

H07 RN-F, H05 RN-F, H05 RRF, H05 VV-F, H05 V2V2-F (T90), H05 BB-F

Para informações sobre a secção do cabo, consulte a potência total na placa de características. Também pode consultar a tabela:

Potência total (W)	Secção do cabo (mm ²)
máximo de 1380	3 x 0.75
máximo de 2300	3 x 1
máximo de 3680	3 x 1.5

O cabo de terra (cabo verde/amarelo) tem de ser 2 cm mais comprido do que os cabos de fase e neutro (cabos azul e castanho).

2.3 Utilização



AVISO!

Risco de ferimentos, queimaduras, choque eléctrico ou explosão.

- Este aparelho destina-se apenas a uso doméstico.

- Não altere as especificações deste aparelho.
- Certifique-se de que as aberturas de ventilação não ficam obstruídas.
- Não deixe o aparelho a funcionar sem vigilância.
- Desative o aparelho após cada utilização.
- Tenha cuidado sempre que abrir a porta do aparelho quando ele estiver a funcionar. Pode sair ar muito quente.
- Não utilize o aparelho com as mãos húmidas ou se ele estiver em contacto com água.
- Não exerça pressão sobre a porta se ela estiver aberta.
- Não utilize o aparelho como superfície de trabalho ou armazenamento.
- Abra a porta do aparelho com cuidado. A utilização de ingredientes com álcool pode provocar uma mistura de álcool e ar.
- Evite que faíscas ou chamas entrem em contacto com o aparelho quando abrir a porta.
- Não coloque produtos inflamáveis, ou objetos molhados com produtos inflamáveis, no interior, perto ou em cima do aparelho.



AVISO!

Risco de danos no aparelho.

- Para evitar danos ou descoloração no esmalte:
 - Não coloque recipientes de ir ao forno ou outros objetos diretamente sobre o fundo da cavidade do aparelho.
 - Não coloque folha de alumínio diretamente sobre o fundo da cavidade do aparelho.
 - Não verta água diretamente sobre o aparelho quando ele estiver quente.
 - Não coloque pratos ou alimentos húmidos no aparelho após acabar de cozinhar.
 - Tenha cuidado quando remover ou instalar os acessórios.
- A eventual descoloração do esmalte ou do aço inoxidável não afeta o desempenho do aparelho.
- Utilize um recipiente profundo quando cozer bolos muito húmidos. Caso contrário, os sucos da fruta podem provocar manchas permanentes.
- Este aparelho serve apenas para cozinhar. Não pode ser usado para outras

funções como, por exemplo, aquecimento de divisões.

- Cozinhe sempre com a porta do forno fechada.
- Se o aparelho ficar instalado atrás de uma porta de armário, nunca feche a porta com o aparelho em funcionamento. Se a porta ficar fechada, poderá ocorrer acumulação de calor e humidade que podem danificar o aparelho, os móveis ou o piso. Não feche a porta do armário enquanto o aparelho não tiver arrefecido completamente após utilização.

2.4 Manutenção e limpeza



AVISO!

Risco de ferimentos, incêndio e danos no aparelho.

- Antes de qualquer ação de manutenção, desative o aparelho e desligue a ficha da tomada elétrica.
- Certifique-se de que o aparelho está frio. Existe o risco de quebra dos painéis de vidro.
- Substitua imediatamente os painéis de vidro se estiverem danificados. Contacte um Centro de Assistência Técnica Autorizado.
- Tenha cuidado quando remover a porta do aparelho. A porta é pesada!
- Limpe o aparelho com regularidade para evitar que o material da superfície se deteriore.
- Limpe o aparelho com um pano macio e húmido. Utilize apenas detergentes neutros. Não utilize produtos abrasivos, esfregões, solventes ou objetos metálicos.
- Se utilizar um spray para forno, siga as instruções de segurança da embalagem.

2.5 Iluminação interna



AVISO!

Risco de choque elétrico.

- Relativamente à(s) lâmpada(s) no interior deste produto e às lâmpadas sobressalentes vendidas separadamente: Estas lâmpadas destinam-se a suportar condições físicas extremas em eletrodomésticos, tais como temperatura, vibração, humidade, ou destinam-se a

sinalizar informação relativamente ao estado operacional do aparelho. Não se destinam a ser utilizadas em outras aplicações e não se adequam à iluminação de espaços domésticos.

- Utilize apenas lâmpadas com as mesmas especificações.

2.6 Assistência

- Contacte um Centro de Assistência Técnica Autorizado se for necessário reparar o aparelho.
- Utilize apenas peças de substituição originais.

2.7 Eliminação



AVISO!

Risco de ferimentos ou asfixia.

- Desligue o aparelho da alimentação eléctrica.
- Corte o cabo de alimentação eléctrica do aparelho e elimine-o.
- Remova o trinco da porta para evitar que crianças ou animais de estimação fiquem presos no aparelho.

3. INSTALAÇÃO



AVISO!

Consulte os capítulos relativos à segurança.

3.1 Encastre



YouTube

www.youtube.com/electrolux
www.youtube.com/aeg

How to install your AEG/Electrolux
Oven - Column installation

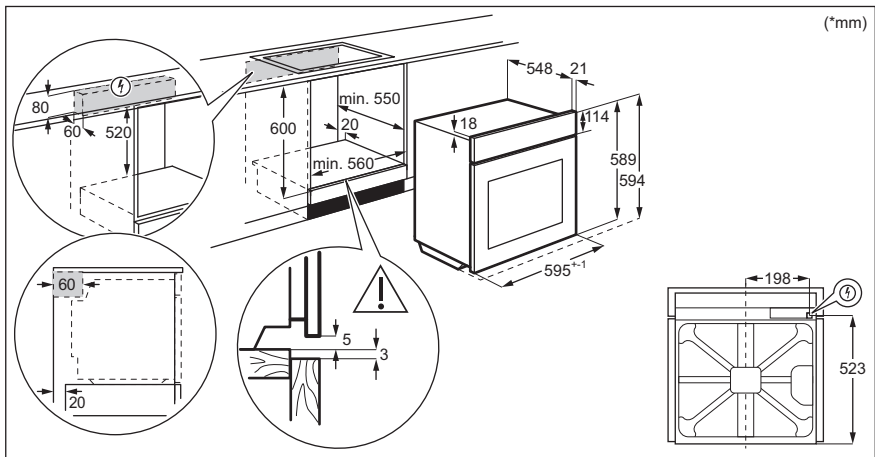

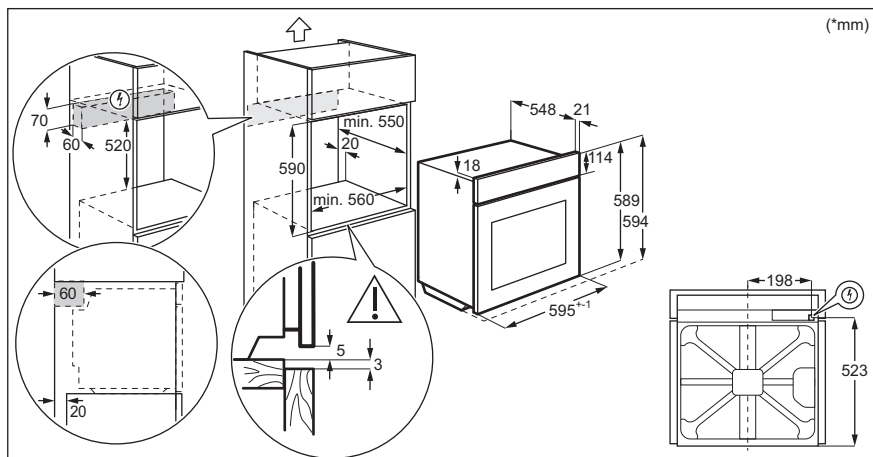

3.2 Fixação do forno no armário

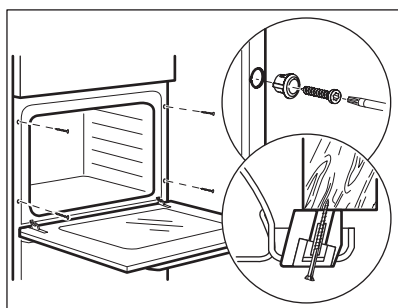

4. DESCRIÇÃO DO PRODUTO

4.1 Visão geral

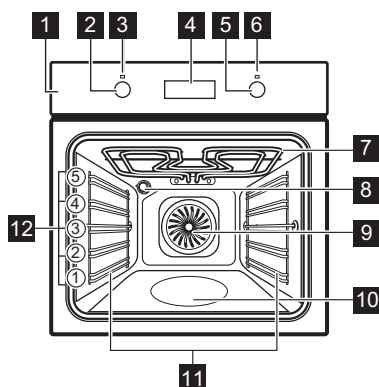

- 1 Painel de controle
- 2 Botão para as funções de aquecimento do forno
- 3 Lâmpada/símbolo de alimentação
- 4 Visor
- 5 Botão de controlo (para a temperatura)
- 6 Símbolo / indicador de temperatura
- 7 Elemento de aquecimento
- 8 Lâmpada
- 9 Ventilador
- 10 Baixo relevo da cavidade - Recipiente da limpeza com água
- 11 Apoio para prateleira, removível
- 12 Posições de prateleira

4.2 Acessórios

- **Prateleira em grelha**
Para recipientes, formas de bolo, assados.
- **Assadeira**
Para bolos e biscoitos. Para cozer e assar ou como recipiente para recolher gordura.

- **Calhas telescópicas**
Com as calhas telescópicas, pode colocar e remover as prateleiras mais facilmente.

5. PAINEL DE COMANDOS

5.1 Botões retráteis

Para utilizar o aparelho, prima o botão. O botão fica saliente.

5.2 Campos/Botões do sensor

—	Para definir o tempo.
⌚	Para selecionar uma função de relógio.
+	Para definir o tempo.

5.3 Visor

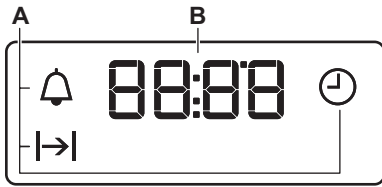

- A. Funções de relógio
- B. Temporizador

6. ANTES DA PRIMEIRA UTILIZAÇÃO



AVISO!

Consulte os capítulos relativos à segurança.

6.1 Antes da primeira utilização

O forno pode emitir algum odor e fumo durante o pré-aquecimento. Certifique-se de que o espaço é ventilado.





Passo 1



Passo 2



Passo 3

Acertar o relógio	Limpeza do forno	Pré-aqueça o forno vazio
<ol style="list-style-type: none">1. +, - - prima para definir o tempo. Após cerca de 5 segundos, o piscar pára e o visor mostra o tempo	<ol style="list-style-type: none">1. Remova todos os acessórios e apoios para prateleiras amovíveis do forno.2. Limpe o forno e os acessórios com um pano macio, água morna e um detergente suave.	<ol style="list-style-type: none">1. Regule a temperatura máxima para a função: . Tempo: 1 h.2. Regule a temperatura máxima para a função: . Tempo: 15 min.3. Regule a temperatura máxima para a função: . Tempo: 15 min.

Desligue o forno e aguarde até estar frio. Coloque os acessórios e apoios de prateleiras amovíveis do forno.

7. UTILIZAÇÃO DIÁRIA



AVISO!

Consulte os capítulos relativos à segurança.

7.1 Como definir: Função de aquecimento

Passo 1 Rode o botão para as funções de aquecimento para selecionar uma função de aquecimento.

Passo 2 Rode o botão de controlo para selecionar a temperatura.

Passo 3 Quando a cozedura terminar, rode os botões para a posição off (desligado) para desligar o forno.

7.2 Tipos de aquecimento

Tipo de aquecimento Aplicação

0

O forno está desligado.

Posição off (desligado)



Luz

Para ativar a lâmpada:



Ventilado com Resistência

Esta função foi concebida para poupar energia durante o cozinhado. Quando utilizar esta função, a temperatura na cavidade pode diferir a temperatura definida. É utilizado o calor residual. A potência do aquecimento pode ser reduzida. Para mais informações consulte o capítulo "Utilização diária", notas sobre: Ventilado com Resistência.



Aquecimento Ventilado

Para cozer em até três posições de prateleira ao mesmo tempo e para secar alimentos. Defina a temperatura do forno entre 20 °C - 40 °C a menos do que Cozedura Convencional.



Aquecimento inferior

Para cozer bolos com bases esmalçadas e conservar alimentos.



Turbo Grill

Para assar peças de carne grandes ou aves com ossos numa posição da prateleira. Para fazer gratinados e alourar.

Tipo de aquecimento Aplicação



Função Pizza

Para cozer pizza. Para um tostado intenso e uma base crocante.



Descongelar

Para descongelar alimentos (legumes e fruta). O tempo de descongelação depende da quantidade e do tamanho dos alimentos congelados.



Grelhador rápido

Para grelhar alimentos finos em grandes quantidades e tostar pão.



Cozedura Convencional / Limpeza com água

Para cozer e assar pratos numa posição de prateleira. Consulte o capítulo "Cuidados e limpeza" para mais informações sobre: Limpeza com água.

7.3 Notas sobre: Ventilado com Resistência

Esta função foi utilizada para cumprir com os requisitos de classe de eficiência energética e design ecológico de acordo com as normas EU 65/2014 e EU 66/2014. Testes de acordo com a norma EN 60350-1.



A porta do forno deve estar fechada durante a cozedura para que a função não seja interrompida e o forno funcione com a mais alta eficiência energética possível.

Quando utiliza esta função a lâmpada é automaticamente desativada.

Para instruções de cozedura, consulte o capítulo "Sugestões e dicas", Ventilado com Resistência. Para recomendações gerais sobre poupança de energia, consulte o capítulo "Eficiência energética", Poupança de energia.

8. FUNÇÕES DE RELÓGIO

8.1 Funções de relógio



Função de relógio	Aplicação
 Hora do dia	Para definir, alterar ou verificar a hora do dia.
 Duração	Para definir o tempo de funcionamento do forno.
 Conta-Minutos	Para definir uma contagem decrescente. Esta função não afeta o funcionamento do forno. Pode regular esta função a qualquer momento, mesmo com o forno desligado.



8.2 Como definir: Funções de relógio

Como alterar: Hora do dia

 - pisca quando ligar o forno à alimentação elétrica, após uma falha de corrente ou se o temporizador não estiver configurado, o indicador fica intermitente.

Passo 1  - prima repetidamente.  - começa a piscar.





Passo 2  ,  - prima para definir o tempo.
Após cerca de 5 segundos, o piscar pára e o visor mostra o tempo

 - prima repetidamente para alterar a hora do dia.  - começa a piscar.

Como definir: Duração

Passo 1 Selecione uma função do forno e a temperatura.

Passo 2  - prima repetidamente.  - começa a piscar.



Passo 3  ,  - prima para definir a duração.
O visor mostra: 
 - pisca quando o tempo definido termina. O sinal soa e o forno desliga-se.

Passo 4 Prima qualquer botão para parar o sinal.

Passo 5 Rode os botões para a posição Off.

Como definir: Conta-Minutos

Passo 1  - prima repetidamente.  - começa a piscar.

Passo 2  ,  - prima para definir o tempo.
A função começa automaticamente após 5 segundos.
Quando o tempo definido terminar, é emitido um sinal sonoro.

Passo 3 Prima qualquer botão para parar o sinal.

Como definir: Conta-Minutos

Passo 4 Rode os botões para a posição Off.

Como cancelar: Funções de relógio

Passo 1  - prima repetidamente até o símbolo da função do relógio começar a piscar.

Passo 2 Prima continuamente: .
A função do relógio desliga-se após alguns segundos.

9. UTILIZAR OS ACESSÓRIOS



AVISO!

Consulte os capítulos relativos à segurança.

9.1 Inserir acessórios

Um pequeno entalhe na parte inferior aumenta a segurança. Estes entalhes são

também dispositivos anti-inclinação. A armação elevada à volta da prateleira impede que os recipientes deslizem para fora da prateleira.

Prateleira em grelha:

Introduza a prateleira entre as barras-guia dos apoios para prateleiras e certifique-se de que os pés de apoio ficam para baixo.

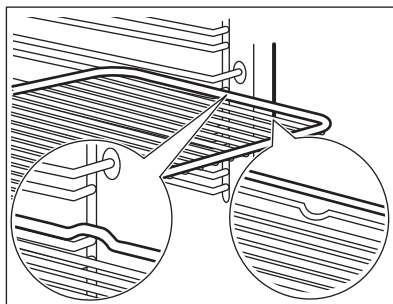

Tabuleiro para grelhar:

Introduza o tabuleiro entre as barras-guia do apoio para prateleiras.

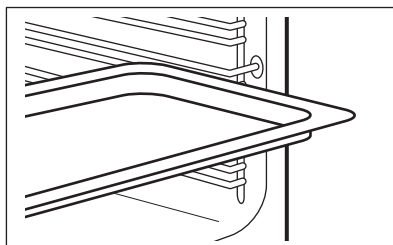

Prateleira em grelha, Tabuleiro para grelhar:
Introduza o tabuleiro entre as barras-guia dos apoios para prateleiras e a prateleira em grelha sobre as barras imediatamente acima.

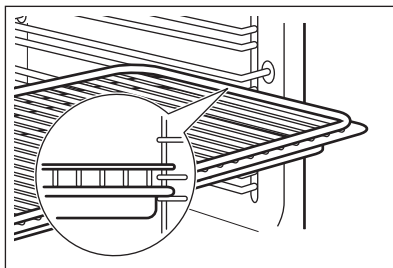

9.2 Utilizar as calhas telescópicas

Não lubrifique as calhas telescópicas.

Certifique-se de que volta a colocar as calhas telescópicas totalmente no interior do forno antes de fechar a porta do forno.

Passo 1 Retire as calhas telescópicas direita e esquerda.

Passo 2 Coloque a prateleira em grelha nas calhas telescópicas e empurre-as cuidadosamente para o interior do forno.

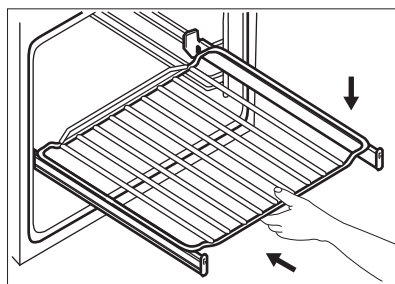
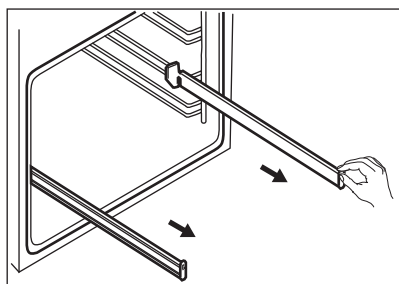

10. FUNÇÕES ADICIONAIS

10.1 Ventoinha de arrefecimento

Quando o forno está a funcionar, a ventoinha de arrefecimento é ativada automaticamente para manter as superfícies do forno frias. Se desligar o forno, a ventoinha de arrefecimento pode continuar a funcionar até o forno arrefecer.

10.2 Termóstato de segurança

Se o forno for utilizado incorretamente ou tiver alguma anomalia, pode ocorrer um

sobreaquecimento perigoso. Para evitar isso, o forno possui um termóstato de segurança que corta a alimentação elétrica. O forno volta a ativar-se automaticamente quando a temperatura baixar.

11. SUGESTÕES E DICAS



Consulte os capítulos relativos à segurança.

11.1 Recomendações para cozinhar

O forno possui cinco posições de prateleira.

Conte as posições de prateleira a partir do fundo do forno.

O forno pode ter um processo para cozer ou assar diferente do forno que utilizava anteriormente. As tabelas em baixo indicam regulações de temperatura, tempos de cozedura e posições de prateleira para algumas receitas comuns.

Se não encontrar as regulações para alguma receita específica, procure uma semelhante.

O forno possui um sistema especial que faz circular o ar e renova constantemente o vapor. Este sistema permite cozinhar num ambiente a vapor e manter os alimentos macios por dentro e estaladiços por fora. Diminui o tempo de cozedura e o consumo de energia.

Cozer bolos

Não abra a porta do forno até ter decorrido 3/4 do tempo de cozedura.

11.2 Fazer bolos e assar

Se utilizar dois tabuleiros para assar em simultâneo, mantenha um nível vazio entre os mesmos.

Cozinhar carne e peixe

Utilize um tabuleiro para grelhar quando cozinhar alimentos muito gordurosos, para evitar que o forno fique com manchas que podem ser permanentes.

Deixe a carne repousar cerca de 15 minutos antes de a cortar, para não perder os sucos.







Para evitar demasiado fumo no forno quando assar, coloque um pouco de água no tabuleiro para grelhar. Para evitar a condensação de fumo, acrescente água sempre que ele seque.

Tempos de cozedura







Os tempos de cozedura dependem do tipo de alimento, da consistência e do volume.

No início, monitorize o desempenho quando cozinhar. Quando utilizar este aparelho, procure as melhores regulações (grau de cozedura, tempo de cozedura, etc.) para os seus recipientes e para as suas receitas e quantidades.

Bolos	Cozedura Convencional		Aquecimento Ventilado		Tempo (min)	Forma de bolo
	Tempo (°C)	Posição	Tempo (°C)	Posição		
Receitas batidas	170	2	160	3 (2 e 4)	45 - 60	Forma de bolo
Massa amanteigada	170	2	160	3 (2 e 4)	20 - 30	Forma de bolo
Cheesecake buttermilk	170	1	165	2	60 - 80	Forma de bolo, Ø 26 cm
Strudel	175	3	150	2	60 - 80	Tabuleiro para assar
Torta de compota	170	2	165	2	30 - 40	Forma de bolo, Ø 26 cm







 BO- LOS	Cozedura Convencional		Aquecimento Ventilado		 (min)	
	 (°C)		 (°C)			
Bolo-rei, pré-aqueça o forno vazio	160	2	150	2	90 - 120	Forma de bolo, Ø 20 cm
Bolo de ameixa, pré-aqueça o forno vazio	175	1	160	2	50 - 60	Forma retangular
Queques	170	3	140 - 150	3	20 - 30	Tabuleiro para assar
Queques, dois níveis	-	-	140 - 150	2 e 4	25 - 35	Tabuleiro para assar
Queques, três níveis	-	-	140 - 150	1, 3 e 5	30 - 45	Tabuleiro para assar
Biscoitos	140	3	140 - 150	3	30 - 35	Tabuleiro para assar
Biscoitos, dois níveis	-	-	140 - 150	2 e 4	35 - 40	Tabuleiro para assar
Biscoitos, três níveis	-	-	140 - 150	1, 3 e 5	35 - 45	Tabuleiro para assar
Merengue	120	3	120	3	80 - 100	Tabuleiro para assar
Merengue, dois níveis, pré-aqueça o forno vazio	-	-	120	2 e 4	80 - 100	Tabuleiro para assar
Pãezinhos, pré-aqueça o forno vazio	190	3	190	3	12 - 20	Tabuleiro para assar
Éclairs	190	3	170	3	25 - 35	Tabuleiro para assar
Éclairs, dois níveis	-	-	170	2 e 4	35 - 45	Tabuleiro para assar
Tartes	180	2	170	2	45 - 70	Forma de bolo, Ø 20 cm
Bolo de fruta rico	160	1	150	2	110 - 120	Forma de bolo, Ø 24 cm

Pré-aqueça o forno vazio.

 PÃO E PIZZA	Cozedura Convencional		Aquecimento Ventilado		 (min)	
	 (°C)		 (°C)			
Pão branco, 1 - 2 unidades, 0,5 kg cada	190	1	190	1	60 - 70	-
Pão de centeio, não é necessário pré-aquecer	190	1	180	1	30 - 45	Forma retangular
Pãezinhos, 6 - 8 pãezinhos	190	2	180	2 (2 e 4)	25 - 40	Tabuleiro para assar
Pizza massa fina	230 - 250	1	230 - 250	1	10 - 20	Tabuleiro esmaltado
Scones	200	3	190	3	10 - 20	Tabuleiro para assar





Pré-aqueça o forno vazio.





Utilize uma forma de bolo.







 FLANS	Cozedura Convencional		Aquecimento Ventilado		 (min)
	 (°C)		 (°C)		
Empadas, não é necessário pré-aquecer	200	2	180	2	40 - 50
Flan de vegetais, não é necessário pré-aquecer	200	2	175	2	45 - 60
Quiches	180	1	180	1	50 - 60
Lasanha	180 - 190	2	180 - 190	2	25 - 40
Canelones	180 - 190	2	180 - 190	2	25 - 40

Utilize a segunda posição da prateleira.





Utilize a prateleira em grelha.

 CARNE	Cozedura Convencional		Aquecimento Ventilado	
	 (°C)		 (°C)	
Carne De Vaca	200		190	
Lombo de porco	180		180	

 CARNE	Cozedura Convencional	Aquecimento Ventilado	 (min)
	 (°C)	 (°C)	
Vitela	190	175	90 - 120
Carne assada, mal passada	210	200	50 - 60
Carne assada, média	210	200	60 - 70
Carne assada, bem passada	210	200	70 - 75

 CARNE	Cozedura Convencional		Aquecimento Ventilado		 (min)
	 (°C)		 (°C)		
Pá de porco, com courato	180	2	170	2	120 - 150
Perna de porco, 2 unidades	180	2	160	2	100 - 120
Perna de borrego	190	2	175	2	110 - 130
Frango inteiro	220	2	200	2	70 - 85
Peru inteiro	180	2	160	2	210 - 240
Pato inteiro	175	2	220	2	120 - 150
Ganso inteiro	175	2	160	1	150 - 200
Coelho, cortado em pedaços	190	2	175	2	60 - 80
Lebre, cortada em pedaços	190	2	175	2	150 - 200
Faisão inteiro	190	2	175	2	90 - 120

Utilize a segunda posição da prateleira.

 PEIXE	Cozedura Convencional	Aquecimento Ventilado	 (min)
	 (°C)	 (°C)	
Truta / Dourada, 3 - 4 peixes	190	175	40 - 55
Atum / Salmão, 4 - 6 filetes	190	175	35 - 60

11.3 Grelhador

Pré-aqueça o forno vazio.

Utilize a quarta posição da prateleira.

Grelhador com a regulação de temperatura máxima.



GRELHAR



(kg)



(min)
1.º lado



(min)
2.º lado

Bifes do lombo, 4 unidades	0,8	12 - 15	12 - 14
Bife de vaca, 4 unidades	0,6	10 - 12	6 - 8
Salgados, 8	-	12 - 15	10 - 12
Costeleta de porco, 4 unidades	0,6	12 - 16	12 - 14
1/2 Frango, 2	1	30 - 35	25 - 30
Espetadas, 4	-	10 - 15	10 - 12
Peito de frango, 4 unidades	0,4	12 - 15	12 - 14
Hambúrgueres, 6	0,6	20 - 30	-
Filete de peixe, 4 unidades	0,4	12 - 14	10 - 12
Sandes tostadas, 4 - 6	-	5 - 7	-
Tosta, 4 - 6	-	2 - 4	2 - 3

11.4 Turbo Grill

Pré-aqueça o forno vazio.

Utilize a primeira e a segunda posições da prateleira

Para calcular o tempo do assado, multiplique o tempo dado na tabela abaixo pelos centímetros de espessura do filete.



CARNE DE VACA



(°C)



(min)

Carne assada ou lombo, mal passado	190 - 200	5 - 6
Carne assada ou lombo, médio	180 - 190	6 - 8
Carne assada ou lombo, bem passado	170 - 180	8 - 10



PORCO



(°C)



(min)

Pá / Cachaço / Fiambre, 1 - 1,5 kg	160 - 180	90 - 120
Costeletas / Entrecosto, 1 - 1,5 kg	170 - 180	60 - 90



PORCO



(°C)



(min)

Rolo de carne, 0,75 - 1 kg	160 - 170	50 - 60
Joelho de porco, pré-cozido, 0,75 - 1 kg	150 - 170	90 - 120



VITELA



(°C)



(min)

Vitela assada, 1 kg	160 - 180	90 - 120
Mão de vitela, 1,5 - 2 kg	160 - 180	120 - 150



CORDEIRO









(°C)





(min)





Perna de borrego / Borrego assado, 1 - 1,5 kg	150 - 170	100 - 120
Lombo de borrego, 1 - 1,5 kg	160 - 180	40 - 60

 AVES	 (°C)	 (min)
Aves, partes, 0,2 - 0,25 kg cada	200 - 220	30 - 50
1/2 Frango, 0,4 - 0,5 kg cada	190 - 210	35 - 50
Frango, galinha, 1 - 1,5 kg	190 - 210	50 - 70
Pato, 1,5 - 2 kg	180 - 200	80 - 100
Ganso, 3,5 - 5 kg	160 - 180	120 - 180

 AVES	 (°C)	 (min)
Peru, 2,5 - 3,5 kg	160 - 180	120 - 150
Peru, 4 - 6 kg	140 - 160	150 - 240

 PEIXE (AO VAPOR)	 (°C)	 (min)
Peixe, inteiro (até 1Kg), 1 - 1,5 kg	210 - 220	40 - 60

11.5 Descongelar

	 (kg)	 Tempo de descongelamento (min.)	 Tempo extra de descongelamento (min.)	
Frango	1	100 - 140	20 - 30	Coloque o frango sobre um pires virado ao contrário e este sobre um prato grande. Vire a meio do tempo.
Carne	1	100 - 140	20 - 30	Vire a meio do tempo.
	0,5	90 - 120		
Natas	2 x 0,2	80 - 100	10 - 15	Também é possível bater as natas quando ainda estão ligeiramente congeladas.
Truta	0,15	25 - 35	10 - 15	-
Morangos	0,3	30 - 40	10 - 20	-
Manteiga	0,25	30 - 40	10 - 15	-
Gateau	1,4	60	60	-



11.6 Secagem - Aquecimento Ventilado



Cubra os tabuleiros com papel impermeável à gordura ou papel vegetal.

Para obter o melhor resultado, desligue o forno a meio do tempo de secagem, abra a porta e deixe arrefecer durante uma noite para acabar de secar.

Para 1 tabuleiro, utilize a terceira posição da prateleira.



Para 2 tabuleiros, utilize a primeira e quarta posições da prateleira.

 LEGUMES	 (°C)	 (h)
Feijões	60 - 70	6 - 8
Pimentos	60 - 70	5 - 6

 LEGUMES	 (°C)	 (h)
Legumes para sopa	60 - 70	5 - 6
Cogumelos	50 - 60	6 - 8
Ervas aromáticas	40 - 50	2 - 3

Defina a temperatura para 60 - 70 °C.

 FRUTA	 (h)
Ameixas	8 - 10

 FRUTA	 (h)
Alperces	8 - 10
Fatias de maçã	6 - 8
Peras	6 - 9

11.7 Ventilado com Resistência - acessórios recomendados

Utilize os tabuleiros e recipientes escuros e não refletores. Têm melhor absorção do calor do que a loiça de cor clara e refletora.



Forma para pizza

Escuro, não refletor
28 cm de diâmetro



Assadeira

Escuro, não refletor
26 cm de diâmetro



Formas individuais

Vitrocerâmica
8 cm de diâmetro,
5 cm de altura

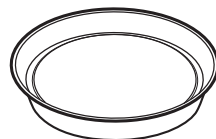











Forma com base para flan

Escuro, não refletor
28 cm de diâmetro

11.8 Ventilado com Resistência







Para obter os melhores resultados, siga as sugestões indicadas na tabela abaixo.







		 (°C)		 (min.)
Pastéis doces, 12 unidades	tabuleiro para assar ou tabuleiro para recolha de gorduras	175	3	40 - 50
Pasteis, 9 unidades	tabuleiro para assar ou tabuleiro para recolha de gorduras	180	2	35 - 45
Pizza, congelada, 0,35 kg	prateleira em grelha	180	2	45 - 55
Torta suíça	tabuleiro para assar ou tabuleiro para recolha de gorduras	170	2	30 - 40

		 (°C)		 (min.)
Brownie	tabuleiro para assar ou tabuleiro para recolha de gorduras	170	2	45 - 50
Soufflé, 6 unidades	formas pequenas de cerâmica na prateleira em grelha	190	3	45 - 55
Base de flan de massa batida	forma de base de flan na prateleira em grelha	180	2	35 - 45
Bolo de duas camadas	assadeira na prateleira em grelha	170	2	35 - 50
Peixe escalfado, 0,3 kg	tabuleiro para assar ou tabuleiro para recolha de gorduras	180	2	35 - 45
Peixe, inteiro (até 1Kg), 0,2 kg	tabuleiro para assar ou tabuleiro para recolha de gorduras	180	3	25 - 35
Filete de peixe, 0,3 kg	forma de piza na prateleira em grelha	170	3	30 - 40
Carne escalfada, 0,25 kg	tabuleiro para assar ou tabuleiro para recolha de gorduras	180	3	35 - 45
Shashlik, 0,5 kg	tabuleiro para assar ou tabuleiro para recolha de gorduras	180	3	40 - 50
Biscoitos, 16 unidades	tabuleiro para assar ou tabuleiro para recolha de gorduras	150	2	30 - 45
Biscoitos de amêndoa, 20 unidades	tabuleiro para assar ou tabuleiro para recolha de gorduras	180	2	45 - 55
Queques, 12 unidades	tabuleiro para assar ou tabuleiro para recolha de gorduras	170	2	30 - 40
Pastelaria salgada, 16 unidades	tabuleiro para assar ou tabuleiro para recolha de gorduras	170	2	35 - 45
Biscoitos de massa fina, 20 unidades	tabuleiro para assar ou tabuleiro para recolha de gorduras	150	2	40 - 50
Tarteletes, 8 unidades	tabuleiro para assar ou tabuleiro para recolha de gorduras	170	2	30 - 40
Legumes, escalfados, 0,4 kg	tabuleiro para assar ou tabuleiro para recolha de gorduras	180	2	35 - 45
Omeleta de legumes	forma de piza na prateleira em grelha	180	3	35 - 45
Legumes mediterrânicos, 0,7 kg	tabuleiro para assar ou tabuleiro para recolha de gorduras	180	4	35 - 45

11.9 Informação para testes

Testes de acordo com a norma IEC 60350-1.

						
				(°C)	(min)	
Bolos pequenos, 20 por tabuleiro	Cozedura Convencional	Tabuleiro para assar	3	170	20 - 30	-
Bolos pequenos, 20 por tabuleiro	Aquecimento Ventilado	Tabuleiro para assar	3	150 - 160	20 - 35	-
Bolos pequenos, 20 por tabuleiro	Aquecimento Ventilado	Tabuleiro para assar	2 e 4	150 - 160	20 - 35	-
Tarte de maçã, 2 formas, Ø 20 cm	Cozedura Convencional	Prateleira em grelha	2	180	70 - 90	-
Tarte de maçã, 2 formas, Ø 20 cm	Aquecimento Ventilado	Prateleira em grelha	2	160	70 - 90	-
Pão-de-ló, forma de bolo de Ø26 cm	Cozedura Convencional	Prateleira em grelha	2	170	40 - 50	Pré-aqueça o forno durante 10 minutos.
Pão-de-ló, forma de bolo de Ø26 cm	Aquecimento Ventilado	Prateleira em grelha	2	160	40 - 50	Pré-aqueça o forno durante 10 minutos.
Pão-de-ló, forma de bolo de Ø26 cm	Aquecimento Ventilado	Prateleira em grelha	2 e 4	160	40 - 60	Pré-aqueça o forno durante 10 minutos.
Massa amanteigada	Aquecimento Ventilado	Tabuleiro para assar	3	140 - 150	20 - 40	-
Massa amanteigada	Aquecimento Ventilado	Tabuleiro para assar	2 e 4	140 - 150	25 - 45	-
Massa amanteigada	Cozedura Convencional	Tabuleiro para assar	3	140 - 150	25 - 45	-
Tosta, 4 - 6 unidades	Grelhador	Prateleira em grelha	4	máx.	2 - 3 minutos para o primeiro lado; 2 - 3 minutos para o segundo lado	Pré-aqueça o forno durante 3 minutos.

				 (°C)	 (min)	
Hambúrguer de vaca, 6 unidades, 0,6 kg	Grelhador	Prateleira em grelha e tabuleiro de recolha de gorduras	4	máx.	20 - 30	Coloque a prateleira em grelha no quarto nível e o tabuleiro de recolha de gorduras no terceiro nível do forno. Vire os alimentos a meio do tempo de cozedura. Pré-aqueça o forno durante 3 minutos.

12. MANUTENÇÃO E LIMPEZA



AVISO!

Consulte os capítulos relativos à segurança.

12.1 Notas sobre a limpeza



Agentes de limpeza

Limpe a parte da frente do forno com um pano macio com água morna e um detergente suave. Limpe e verifique a junta da porta em torno da moldura da cavidade.

Utilize uma solução de limpeza para limpar as superfícies metálicas.

Limpe manchas com um detergente suave.



Utilização diária

Limpe a cavidade após cada utilização. A acumulação de gordura ou outros resíduos pode provocar incêndios.

Pode ocorrer condensação de humidade no forno ou nos painéis de vidro da porta. Para diminuir a condensação, deixe o forno funcionar durante 10 minutos antes da cozedura. Não guarde alimentos no forno durante mais de 20 minutos. Seque a cavidade com um pano macio após cada utilização.



Acessórios

Limpe todos os acessórios do forno após cada utilização e deixe-os secar. Utilize um pano macio com água morna e um detergente suave. Não lave os acessórios na máquina de lavar loiça.

Não limpe acessórios anti-aderentes utilizando detergentes abrasivos ou objetos afiados.

12.2 Como remover: Apoios para prateleiras

Retire os apoios para prateleiras para limpar o forno.

Passo 1 Desligue o forno e aguarde até estar frio.

Passo 2 Puxe a parte de frente do apoio para prateleiras para fora da parede lateral.

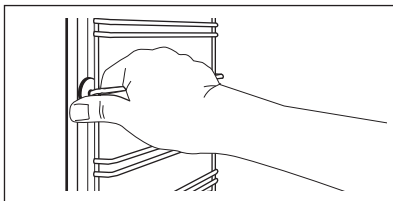

Passo 3 Puxe a parte de trás do apoio para prateleiras para fora da parede lateral e retire-o.

Passo 4 Instale os apoios para grelhas na sequência inversa. Os pinos de fixação das calhas telescópicas devem ficar virados para a parte da frente.

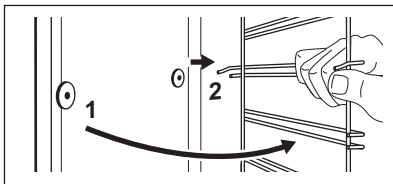

12.3 Como utilizar: Limpeza com água

Este procedimento de limpeza utiliza humidade para remover gordura e partículas de alimentos do forno.

Passo 1 Verta água para o baixo relevo da cavidade: 300 ml.

Passo 2 Selecione a função:

Passo 3 Regule a temperatura para 90 °C.

Passo 4 Deixe o forno funcionar durante 30 min.

Passo 5 Desligue o forno.

Passo 6 Aguarde até que o forno esteja frio. Seque a cavidade com um pano macio.

12.4 Como remover e instalar: Porta

A porta do forno tem dois painéis de vidro. Pode remover a porta do forno e o painel de vidro interno para limpar. Leia todas as instruções sobre "Remoção e instalação da porta" antes de remover os painéis de vidro.



CUIDADO!

Não utilize o forno sem os painéis de vidro.

Passo 1 Abra completamente a porta e segure em ambas as dobradiças.

Passo 2 Levante e rode as alavancas totalmente em ambas as dobradiças.

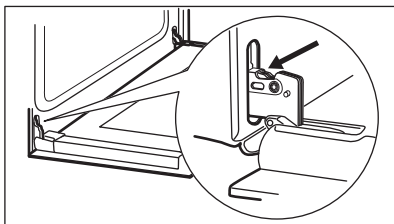

Passo 3 Feche a porta do forno até meio, parando na primeira posição de abertura. Em seguida, levante e puxe a porta e remova-a dos encaixes.

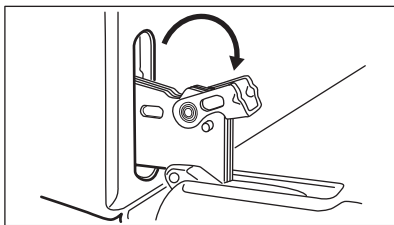

Passo 4 Coloque a porta numa superfície estável protegida por um pano macio.

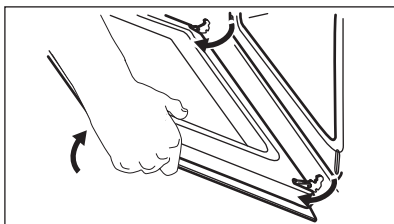

Passo 5 Segure no friso da porta (B) no rebordo superior da porta, nos dois lados, e pressione para dentro para soltar o fecho de encaixe.



Passo 6 Puxe o friso da porta para a frente para o remover.

Passo 7 Segure na extremidade superior do painel de vidro da porta e puxe-o para fora com cuidado. Certifique-se de que o vidro desliza totalmente para fora dos suportes.

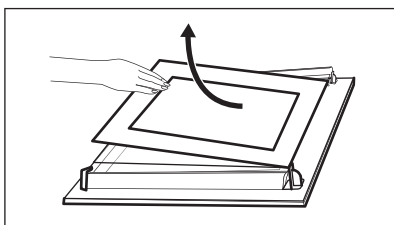

Passo 8 Limpe os painéis de vidro com água e sabão. Seque cuidadosamente os painéis de vidro. Não lave os acessórios na máquina de lavar loiça.

Passo 9 Após a limpeza, instale o painel de vidro e a porta do forno.

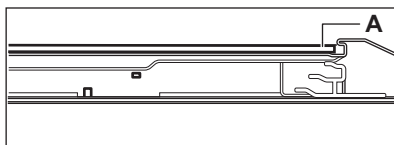

A zona com a impressão em relevo tem de ficar voltada para o lado interior da porta. Certifique-se de que, após a instalação, a superfície da moldura do painel de vidro nas zonas da impressão em relevo não é rugosa.

Quando instalado corretamente, o friso para porta emite um clique. Certifique-se de que instala o painel de vidro interior corretamente nos respetivos encaixes.

12.5 Como substituir: Lâmpada



AVISO!

Risco de choque elétrico.
A lâmpada pode estar quente.

Segure sempre a lâmpada de halogéneo com um pano para evitar a queima de resíduos de gordura na lâmpada.

Antes de substituir a lâmpada:

Passo 1	Passo 2	Passo 3
Desligue o forno. Aguarde até que o forno esteja frio.	Desligue o forno da corrente elétrica.	Coloque um pano no fundo da cavidade.

Lâmpada posterior

Passo 1 Rode a proteção de vidro para a retirar.

Passo 2 Limpe a proteção de vidro.

Passo 3 Substitua a lâmpada por uma lâmpada adequada, resistente ao calor até 300 °C.

Passo 4 Instale a proteção de vidro.

13. RESOLUÇÃO DE PROBLEMAS



AVISO!

Consulte os capítulos relativos à segurança.

13.1 O que fazer se...

Em quaisquer casos não incluídos nesta tabela, contacte um centro de assistência autorizado.

Problema	Certifique-se de que...
O forno não aquece.	O disjuntor está desligado.
A junta da porta está danificada.	Não utilize o forno. Contacte um Centro de Assistência Técnica Autorizado.
O visor apresenta "12.00".	Houve uma falha de corrente eléctrica. Definir a hora do dia.

Problema

Certifique-se de que...

A lâmpada não funciona. A lâmpada está fundida.

13.2 Dados para a Assistência Técnica

Se não conseguir encontrar uma solução para o problema, contacte o concessionário ou um Centro de Assistência Técnica Autorizado.

Os dados de contacto do Centro de Assistência Técnica encontram-se na placa de características. A placa de características está na moldura frontal da cavidade do forno. Não remova a placa de características da cavidade do forno.

Recomendamos que anote os dados aqui:

Modelo (MOD.)

Recomendamos que anote os dados aqui:

Número do produto (PNC)

Número de série (S.N.)

14. EFICIÊNCIA ENERGÉTICA

14.1 Informação de produto e folha de informação de produto*

Nome do fornecedor	Electrolux	
Identificação do modelo	EOF3H54X 949496302 KOF54X 949496300	
Índice de eficiência energética	81.2	
Classe de eficiência energética	A+	
Consumo de energia com uma carga normal, modo convencional	0.93 kWh/ciclo	
Consumo de energia com uma carga normal, modo ventilado	0.69 kWh/ciclo	
Número de cavidades	1	
Fonte de calor	Eletricidade	
Volume	72 l	
Tipo de forno	Forno de encastrar	
Massa	EOF3H54X	27.8 kg
	KOF54X	27.5 kg

* Para a União Europeia de acordo com os Regulamentos 65/2014 e 66/2014 da UE.

Para a República da Bielorrússia de acordo com a norma STB 2478-2017, Anexo G; STB 2477-2017, Anexos A e B.

Para a Ucrânia de acordo com a norma 568/32020.

A classe de eficiência energética não se aplica na Rússia.

EN 60350-1 - Aparelhos elétricos domésticos para cozinhar - Parte 1: Placas, fornos, fornos a vapor e grelhadores - Métodos de medição do desempenho.

14.2 Poupança de energia



O forno possui funções que ajudam a poupar energia nos cozinhados de todos os dias.

Certifique-se de que a porta do forno está fechada quando o forno funcionar. Não abra a porta do forno muitas vezes durante o funcionamento. Mantenha a junta da porta limpa e certifique-se de que está bem fixa na posição correcta.

Utilize recipientes de metal para melhorar a poupança de energia.

Quando possível, não pré-aqueça o forno antes de cozinhar.

Quando preparar vários pratos de uma vez, reduza ao mínimo possível os intervalos entre cozeduras.

Cozinhar com a ventoinha

Sempre que possível, utilize as funções de cozedura que utilizam a ventoinha, para poupar energia.

Calor residual

Quando a duração da cozedura for superior a 30 min, reduza a temperatura do forno para 3 a 10 min no mínimo antes do fim da

cozedura. O calor residual no interior do forno concluirá a cozedura.

Utilize o calor residual para aquecer outros pratos.

Manter os alimentos quentes

Para utilizar o calor residual para manter uma refeição quente, seleccione a regulação de temperatura mais baixa possível.

Ventilado com Resistência

Função concebida para poupar energia durante a cozedura.

Quando utilizar esta função, a lâmpada está desligada.

15. PREOCUPAÇÕES AMBIENTAIS

Recicle os materiais que apresentem o símbolo . Coloque a embalagem nos contentores indicados para reciclagem. Ajude a proteger o ambiente e a saúde pública através da reciclagem dos aparelhos eléctricos e electrónicos. Não elimine os

aparelhos que tenham o símbolo  juntamente com os resíduos domésticos. Coloque o produto num ponto de recolha para reciclagem local ou contacte as suas autoridades municipais.

PENSAMOS EN USTED

Gracias por adquirir un aparato Electrolux. Ha escogido un producto que contiene décadas de experiencia e innovación profesionales. Ingenioso y elegante, se ha diseñado pensando en usted. Así pues, siempre que lo utilice, puede tener la seguridad de que conseguirá excelentes resultados.

Bienvenido a Electrolux.

Visite nuestro sitio web para:



Obtener consejos, folletos, soluciones a problemas e información de servicio y reparación:

www.electrolux.com/support



Registrar su producto para recibir un mejor servicio:

www.registerelectrolux.com



Adquirir accesorios, artículos de consumo y recambios originales para su aparato:

www.electrolux.com/shop

ATENCIÓN Y SERVICIO AL CLIENTE

Le recomendamos que utilice recambios originales.

Al contactar con nuestro centro autorizado de servicio técnico, cerciórese de tener la siguiente información a mano: Modelo, PNC, Número de serie.

La información se puede encontrar en la placa de características.

 Advertencia / Precaución-Información sobre seguridad

 Información general y consejos

 Información sobre el medio ambiente

Salvo modificaciones.

CONTENIDO

1. INFORMACIÓN SOBRE SEGURIDAD.....	56
2. INSTRUCCIONES DE SEGURIDAD.....	57
3. INSTALACIÓN.....	60
4. DESCRIPCIÓN DEL PRODUCTO.....	62
5. PANEL DE MANDOS.....	62
6. ANTES DEL PRIMER USO.....	63
7. USO DIARIO.....	63
8. FUNCIONES DEL RELOJ.....	65
9. USO DE LOS ACCESORIOS.....	66
10. FUNCIONES ADICIONALES.....	67
11. CONSEJOS.....	68
12. MANTENIMIENTO Y LIMPIEZA.....	76
13. SOLUCIÓN DE PROBLEMAS.....	79
14. EFICACIA ENERGÉTICA.....	80

1. ⚠ INFORMACIÓN SOBRE SEGURIDAD

Antes de instalar y utilizar el aparato, lea atentamente las instrucciones facilitadas. El fabricante no se hace responsable de lesiones o daños producidos como resultado de una instalación o un uso incorrectos. Conserve siempre estas instrucciones en lugar seguro y accesible para futuras consultas.

1.1 Seguridad de niños y personas vulnerables

- Este aparato puede ser utilizado por niños de 8 años en adelante y personas cuyas capacidades físicas, sensoriales o mentales estén disminuidas o que carezcan de la experiencia y conocimientos suficientes para manejarlo, siempre que cuenten con las instrucciones o la supervisión sobre el uso del electrodoméstico de forma segura y comprendan los riesgos. Hay que mantener alejados del producto a los niños de menos de 8 años, así como a las personas con minusvalías importantes y complejas, salvo que estén bajo supervisión continua.
- No deje que los niños jueguen con el aparato.
- Mantenga todo el material de embalaje fuera del alcance de los niños y deséchelo de forma adecuada.
- **ADVERTENCIA:** Mantenga a los niños y mascotas alejados del aparato cuando esté funcionando o enfriándose. Las partes accesibles se calientan durante el uso.
- Si este aparato tiene un bloqueo de seguridad para niños, debe activarlo.
- La limpieza y mantenimiento de usuario del aparato no podrán ser realizados por niños sin supervisión.

1.2 Seguridad general

- Solo un electricista cualificado puede instalar este aparato y sustituir el cable.
- **ADVERTENCIA:** El aparato y las piezas accesibles se calientan mucho durante el funcionamiento. Preste mucha atención para no tocar las resistencias.

- Utilice siempre guantes de horno cuando introduzca o retire accesorios o utensilios refractarios.
- Antes de realizar tareas de mantenimiento, desenchufe el aparato de la red eléctrica.
- **ADVERTENCIA:** Asegúrese de que el aparato está desconectado antes de reemplazar la lámpara con el fin de impedir que se produzca una descarga eléctrica.
- No utilice el aparato antes de instalarlo en la estructura empotrada.
- No utilice un limpiador a vapor para limpiar el aparato.
- No utilice limpiadores abrasivos ásperos ni rascadores de metal afilado para limpiar la puerta de cristal si no quiere arañar su superficie, lo que podría hacer que el cristal se hiciese añicos.
- Si el cable de alimentación eléctrica sufre algún daño, el fabricante, su servicio técnico autorizado o un profesional cualificado tendrán que cambiarlo para evitar riesgos eléctricos.
- Para quitar los carriles laterales, tire primero del frontal del carril y luego separe el extremo trasero de las paredes. Coloque los carriles laterales en el orden inverso.

2. INSTRUCCIONES DE SEGURIDAD

2.1 Instalación



ADVERTENCIA!

Sólo un técnico cualificado puede instalar el aparato.

- Retire todo el embalaje.
- No instale ni utilice un aparato dañado.
- Siga las instrucciones de instalación suministradas con el aparato.
- Tenga cuidado al mover el aparato, porque es pesado. Utilice siempre guantes de protección y calzado cerrado.
- No tire nunca del aparato sujetando el asa.
- Instale el aparato en un lugar seguro y adecuado que cumpla los requisitos de instalación.
- Respete siempre la distancia mínima entre el aparato y los demás electrodomésticos y mobiliario.

- Antes de montar el aparato, compruebe si la puerta del horno se abre sin limitaciones.
- El aparato dispone de un sistema de enfriamiento eléctrico. Debe utilizarse con alimentación eléctrica.

Altura mínima del armario (Altura mínima del armario debajo de la encimera)	590 (600) mm
---	--------------

Ancho del armario	560 mm
-------------------	--------

Profundidad del armario	550 (550) mm
-------------------------	--------------

Altura de la parte frontal del aparato	594 mm
---	--------

Altura de la parte trasera del aparato	576 mm
---	--------

Anchura de la parte frontal del aparato	595 mm
Anchura de la parte trasera del aparato	559 mm
Fondo del aparato	569 mm
Fondo empotrado del aparato	548 mm
Fondo con la puerta abierta	1022 mm
Tamaño mínimo de la abertura de ventilación. Abertura situada en la parte trasera inferior	560x20 mm
Longitud del cable de alimentación. El cable está en la esquina derecha de la parte trasera	1500 mm
Tornillos de montaje	4x25 mm

2.2 Conexión eléctrica



ADVERTENCIA!

Riesgo de incendios y descargas eléctricas.

- Todas las conexiones eléctricas deben realizarlas electricistas cualificados.
- El aparato debe conectarse a tierra.
- Asegúrese de que los parámetros de la placa de características son compatibles con los valores eléctricos del suministro eléctrico.
- Utilice siempre una toma con aislamiento de conexión a tierra correctamente instalada.
- No utilice adaptadores de enchufes múltiples ni cables prolongadores.
- Asegúrese de no provocar daños en el enchufe ni en el cable de red. Si es necesario cambiar el cable de alimentación del aparato, debe hacerlo el centro de servicio técnico autorizado.
- Evite que el cable de red toque o entre en contacto con la puerta del aparato o con el hueco por debajo del aparato, especialmente mientras funciona o si la puerta está caliente.
- Los mecanismos de protección contra descargas eléctricas de componentes con corriente y aislados deben fijarse de forma que no puedan aflojarse sin utilizar herramientas.

- Conecte el enchufe a la toma de corriente únicamente cuando haya terminado la instalación. Asegúrese de tener acceso al enchufe del suministro de red una vez finalizada la instalación.
- Si la toma de corriente está floja, no conecte el enchufe.
- No desconecte el aparato tirando del cable de conexión a la red. Tire siempre del enchufe.
- Use únicamente dispositivos de aislamiento apropiados: línea con protección contra los cortocircuitos, fusibles (tipo tornillo que puedan retirarse del soporte), dispositivos de fuga a tierra y contactores.
- La instalación eléctrica debe tener un dispositivo de aislamiento que permita desconectar el aparato de todos los polos de la red. El dispositivo de aislamiento debe tener una apertura de contacto con una anchura mínima de 3 mm.
- El aparato se suministra con enchufe y cable de red.

Tipos de cables aplicables para su instalación o cambio para Europa:

H07 RN-F, H05 RN-F, H05 RRF, H05 VV-F, H05 V2V2-F (T90), H05 BB-F

En lo que respecta a la sección del cable, consulte la potencia total que figura en la placa de características. También puede consultar la tabla:

Potencia total (W)	Sección del cable (mm ²)
máximo 1380	3 x 0.75
máximo 2300	3 x 1
máximo 3680	3 x 1.5

El cable de tierra (cable verde/amarillo) debe tener 2 cm más que los cables de fase y del neutro (cables azul y marrón).

2.3 Uso



ADVERTENCIA!

Riesgo de lesiones, quemaduras y descargas eléctricas o explosiones.

- Este aparato está diseñado exclusivamente para uso doméstico.
- No cambie las especificaciones de este aparato.
- Cerciórese de que los orificios de ventilación no están obstruidos.
- No deje nunca el aparato desatendido mientras está en funcionamiento.
- Desactive el aparato después de cada uso.
- Tenga cuidado al abrir la puerta del aparato cuando éste esté en funcionamiento. Pueden liberarse vapores calientes.
- No utilice el aparato con las manos mojadas ni cuando entre en contacto con el agua.
- No ejerza presión sobre la puerta abierta.
- No utilice el aparato como superficie de trabajo ni de almacenamiento.
- Abra la puerta del aparato con cuidado. El uso de ingredientes con alcohol puede generar una mezcla de alcohol y aire.
- Procure que no haya chispas ni fuego encendido cerca cuando se abra la puerta del aparato.
- No coloque productos inflamables ni objetos mojados con productos inflamables dentro, cerca o encima del aparato.



ADVERTENCIA!

Podría dañar el aparato.

- Para evitar daños o decoloraciones en el esmalte:
 - no coloque utensilios refractarios ni otros objetos directamente en la parte inferior del aparato.
 - no coloque papel de aluminio directamente en la parte inferior del interior del aparato.
 - No ponga agua directamente en el aparato caliente.
 - No deje platos húmedos ni comida en el aparato una vez finalizada la cocción.
 - Preste especial atención al desmontar o instalar los accesorios.
- La pérdida de color del esmalte o el acero inoxidable no afecta al rendimiento del aparato.
- Utilice una bandeja honda para pasteles húmedos. Los jugos de las frutas podrían ocasionar manchas permanentes.

- Este aparato está diseñado exclusivamente para cocinar. No debe utilizarse para otros fines, por ejemplo, como calefacción.
- Cocine siempre con la puerta del horno cerrada.
- Si el aparato se instala detrás de un panel de un mueble (por ejemplo una puerta) asegúrese de que la puerta nunca esté cerrada mientras funciona el aparato. El calor y la humedad pueden acumularse detrás de un panel del armario cerrado y provocar daños al aparato, el alojamiento o el suelo. No cierre del panel del armario hasta que el aparato se haya enfriado completamente después de su uso.

2.4 Mantenimiento y limpieza



ADVERTENCIA!

Existe riesgo de lesiones, incendios o daños al aparato.

- Antes de proceder con el mantenimiento, apague el aparato y desconecte el enchufe de la red.
- Asegúrese de que el aparato esté frío. Los paneles de cristal pueden romperse.
- Cambie inmediatamente los paneles de cristal de la puerta que estén dañados. Póngase en contacto con el servicio técnico autorizado.
- Tenga cuidado al desmontar la puerta del aparato. ¡La puerta es muy pesada!
- Limpie periódicamente el aparato para evitar el deterioro del material de la superficie.
- Limpie el aparato con un paño suave humedecido. Utilice solo detergentes neutros. No utilice productos abrasivos, estropajos duros, disolventes ni objetos metálicos.
- Si utiliza aerosoles de limpieza para hornos, siga las instrucciones de seguridad del envase.

2.5 Luces interiores



ADVERTENCIA!

Riesgo de descarga eléctrica.

- En cuanto a la(s) bombilla(s) de este producto y las de repuesto vendidas por separado: Estas bombillas están destinadas a soportar condiciones físicas

extremas en los aparatos domésticos, como la temperatura, la vibración, la humedad, o están destinadas a señalar información sobre el estado de funcionamiento del aparato. No están destinadas a utilizarse en otras aplicaciones y no son adecuadas para la iluminación de estancias domésticas.

- Utilice solo bombillas de las mismas características .

2.6 Asistencia

- Para reparar el aparato, póngase en contacto con el centro de servicio autorizado.

- Utilice solamente piezas de recambio originales.

2.7 Eliminación



ADVERTENCIA!

Existe riesgo de lesiones o asfixia.

- Desconecte el aparato de la red.
- Corte el cable eléctrico cerca del aparato y deséchelo.
- Retire el pestillo de la puerta para evitar que los niños las mascotas queden atrapados en el aparato.

3. INSTALACIÓN



ADVERTENCIA!

Consulte los capítulos sobre seguridad.

3.1 Empotrado



www.youtube.com/electrolux
www.youtube.com/aeg

How to install your AEG/Electrolux
Oven - Column installation

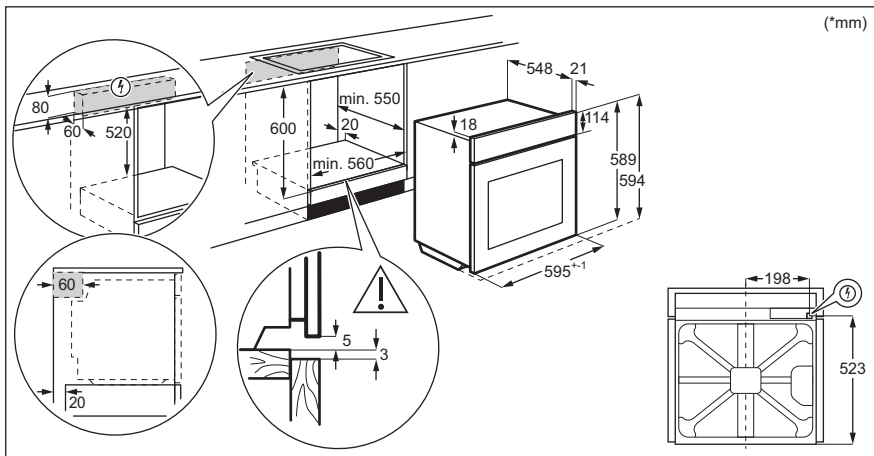

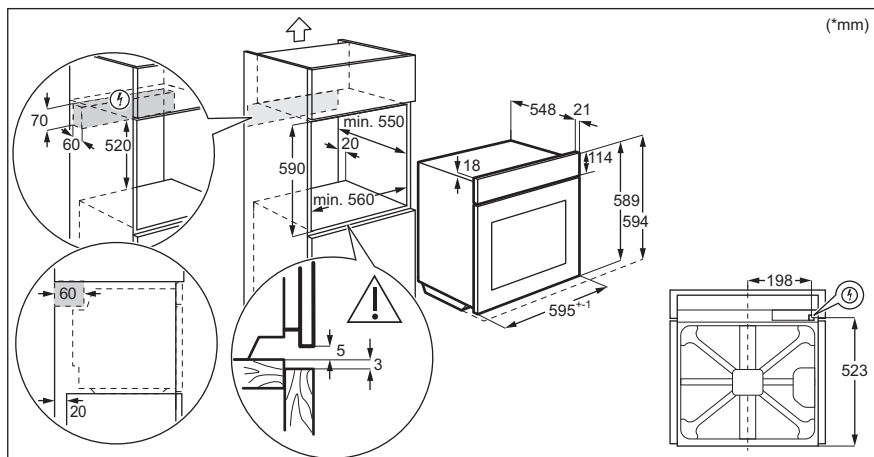

3.2 Fijación del horno al mueble

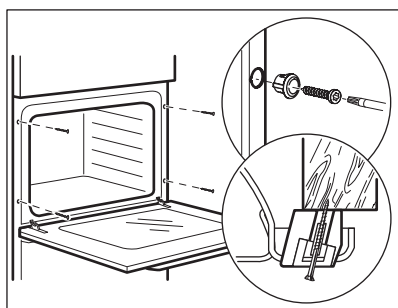

4. DESCRIPCIÓN DEL PRODUCTO

4.1 Descripción general

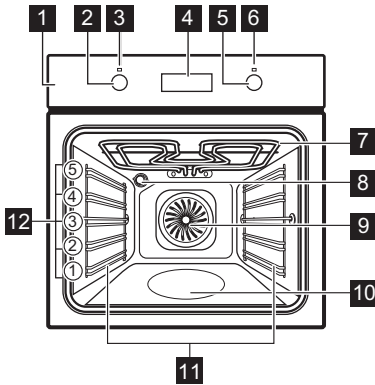

- 1 Panel de control
- 2 Mando de las funciones de cocción
- 3 Piloto/símbolo de alimentación
- 4 Pantalla
- 5 Mando de control (para la temperatura)
- 6 Indicador/símbolo de temperatura
- 7 Elemento calentador
- 8 Bombilla
- 9 Ventilador
- 10 Relieve de la cavidad - Contenedor de limpieza con agua
- 11 Carril de apoyo, extraíble
- 12 Niveles para las rejillas

4.2 Accesorios

- **Parrilla**
Para bandejas de horno, pastel en molde, asados.
- **Bandeja combi**
Para bizcochos y galletas. Para hornear y asar o como bandeja para grasa.

- **Carriles telescópicos**
Con los carriles telescópicos es más fácil colocar y quitar las bandejas.

5. PANEL DE MANDOS

5.1 Mandos escamoteables

Para usar el aparato, presione el mando. El mando sale del alojamiento.

5.2 Sensores / botones

—	Para ajustar la hora.
⌚	Para ajustar una función de reloj.
+	Para ajustar la hora.

5.3 Pantalla

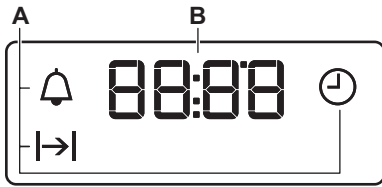

- A. Funciones del reloj
- B. Temporizador

6. ANTES DEL PRIMER USO



ADVERTENCIA!

Consulte los capítulos sobre seguridad.

6.1 Antes del primer uso

El horno puede emitir olores y humos durante el precalentamiento. Asegúrese de que la sala esté ventilada.





Paso 1



Paso 2



Paso 3

Ajuste el reloj	Limpie el horno	Precaliente el horno vacío
1. - pulse + , - para ajustar la hora. Después de unos 5 segundos, el parpadeo cesa y la pantalla indica la hora ajustada.	1. Retire todos los accesorios y carriles de apoyo extraíbles del horno. 2. Limpie el horno y los accesorios con un paño suave humedecido en agua templada y jabón neutro.	1. Seleccione la temperatura máxima para la función:  . Tiempo: 1 h. 2. Seleccione la temperatura máxima para la función:  . Tiempo: 15 min. 3. Seleccione la temperatura máxima para la función:  . Tiempo: 15 min.

Apague el horno y espere a que esté frío. Coloque los accesorios y carriles de apoyo extraíbles en el horno.

7. USO DIARIO



ADVERTENCIA!

Consulte los capítulos sobre seguridad.





7.1 Cómo configurar: Función de cocción





Paso 1 Gire el mando del horno para seleccionar una función de cocción.

Paso 2 Gire el mando de control para seleccionar la temperatura.

Paso 3 Al terminar la cocción, gire los mandos hasta la posición de apagado para apagar el horno.

7.2 Funciones de cocción

Función de cocción	Aplicación
0 Posición de apagado	El horno está apagado.
 Luz	Para encender la luz.
 Horneado húmedo + ventil.	Función diseñada para ahorrar energía durante la cocción. Cuando se utiliza esta función, la temperatura del horno puede diferir de la temperatura programada. Se utiliza el calor residual. La potencia calorífica puede reducirse. Para más información, consulte el capítulo "Uso diario", Notas sobre: Horneado húmedo + ventil..
 Aire caliente	Para hornear en hasta tres posiciones de parrilla a la vez y para secar alimentos. Ajuste la temperatura entre 20 y 40 °C menos que para Cocción convencional.
 Calor inferior	Para preparar pasteles con bases crujientes y conservar alimentos.
 Grill Turbo	Para asar piezas de carne grandes o aves con hueso en una posición de bandeja. Para hacer gratenes y dorar.

Función de cocción	Aplicación
 Función pizza	Para hornear pizza. Para obtener un dorado más intenso y una base más crujiente
 Descongelar	Para descongelar alimentos (verdura y fruta). El tiempo de descongelación depende de la cantidad y tamaño de los alimentos congelados.
 Grill Rápido	Para asar al grill trozos finos de comida en grandes cantidades y tostar pan.
 Cocción convencional / Limpieza con agua	Para hornear y asar alimentos en una posición de bandeja. Consulte el capítulo "Mantenimiento y limpieza" para obtener más información sobre: Limpieza con agua.

7.3 Notas sobre: Horneado húmedo + ventil.

Esta función se utilizaba para cumplir con los requisitos de categoría de eficiencia energética y ecodiseño según EU 65/2014 y EU 66/2014. Pruebas conforme a EN 60350-1.



La puerta del horno debe estar cerrada durante la cocción para que la función no se interrumpa y que el horno funcione con la máxima eficiencia energética posible.

Cuando se utiliza esta función, la bombilla se apaga automáticamente.

Para las instrucciones de cocción, consulte el capítulo "Consejos", Horneado húmedo + ventil.. Puede consultar recomendaciones generales para ahorrar energía en el capítulo "Eficiencia energética", bajo consumo energético.

8. FUNCIONES DEL RELOJ

8.1 Funciones del reloj



función de reloj	Aplicación
 Hora	Ajustar, modificar o comprobar la hora.
 Duración	Programar la duración del funcionamiento del horno.
 Avisador	Para configurar una cuenta atrás. Esta función no influye en el funcionamiento del horno. Puede ajustar esta función cualquier momento, incluso si el horno está apagado.



8.2 Cómo configurar: Funciones del reloj

Cómo cambiar: Hora

 - parpadea al conectar el aparato a la corriente eléctrica si ha habido un corte de corriente o si no está ajustado el temporizador.

Paso 1  - pulse repetidamente.  - empieza a parpadear.





Paso 2 ,  - pulse para ajustar la hora.
Después de unos 5 segundos, el parpadeo cesa y la pantalla indica la hora ajustada.

 - pulse repetidamente para cambiar la hora del día.  - empieza a parpadear.

Cómo configurar: Duración

Paso 1 Programe una función del horno y la temperatura.

Paso 2  - pulse repetidamente.  - empieza a parpadear.



Paso 3 ,  - pulse para establecer la duración.
La pantalla muestra: 
 - parpadea cuando termina el tiempo establecido. La señal suena y el horno se apaga.

Paso 4 Pulse cualquier tecla para desconectar la señal.

Paso 5 Gire los mandos a la posición de apagado.

Cómo configurar: Avisador

Paso 1  - pulse repetidamente.  - empieza a parpadear.

Paso 2 ,  - pulse para ajustar la hora.
La función empieza automáticamente tras 5 segundos.
Al finalizar el tiempo ajustado suena una señal.

Paso 3 Pulse cualquier tecla para desconectar la señal.

Cómo configurar: Avisador

Paso 4 Gire los mandos a la posición de apagado.

Instrucciones para cancelar: Funciones del reloj

Paso 1  - pulse repetidamente hasta que el símbolo de la función de reloj empiece a parpadear.

Paso 2 Mantenga pulsada: .
La función de reloj se apaga después de unos segundos.

9. USO DE LOS ACCESORIOS



ADVERTENCIA!

Consulte los capítulos sobre seguridad.

también son dispositivos anti-vuelco. El borde elevado que rodea la bandeja evita que los utensilios de cocina resbalen de la parrilla.

9.1 Inserción de accesorios

Una pequeña muesca en la parte superior aumenta la seguridad. Las hendiduras

Parrilla:

Inserte la parrilla entre las guías del carril y asegúrese de que las hendiduras apuntan hacia abajo.

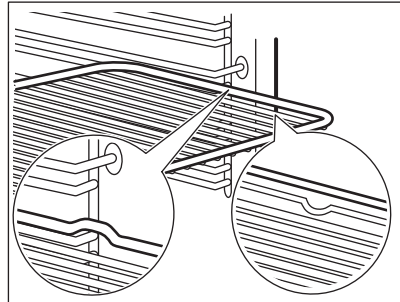

Bandeja honda:

Introduzca la bandeja entre las guías del carril de apoyo.

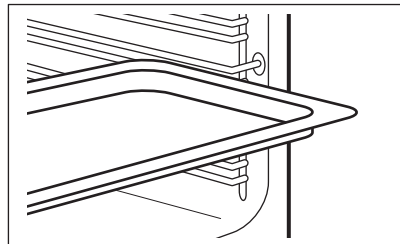

Parrilla, Bandeja honda:

Posicione la bandeja entre las guías del carril de apoyo y la parrilla en las guías de encima.

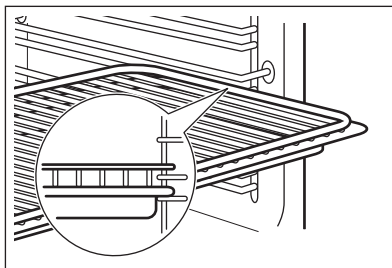

9.2 Utilización de los carriles telescópicos

No lubrique los carriles telescópicos.

Asegúrese de empujar los carriles telescópicos hasta el fondo del horno antes de cerrar la puerta.

Paso 1 Saque los carriles telescópicos de la derecha y la izquierda.

Paso 2 Coloque la parrilla en los carriles telescópicos y luego empuje cuidadosamente para introducirlos en el horno.

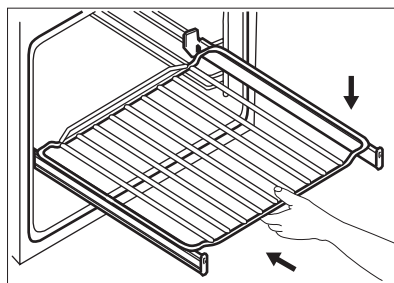
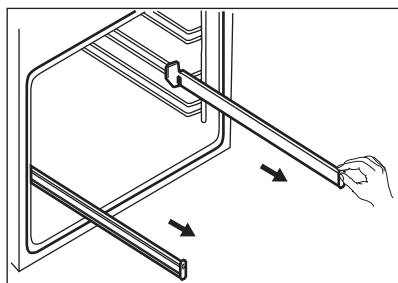

10. FUNCIONES ADICIONALES

10.1 Ventilador de enfriamiento

Cuando el horno funciona, el ventilador de enfriamiento se pone en marcha automáticamente para mantener frías las superficies del horno. Una vez apagado el horno, el ventilador sigue funcionando hasta enfriarlo totalmente.

sobrecalentamientos peligrosos. Para evitarlo, el horno dispone de un termostato de seguridad que interrumpe la alimentación. El horno se vuelve a encender automáticamente cuando desciende la temperatura.

10.2 Termostato de seguridad

El funcionamiento incorrecto del horno o los componentes defectuosos pueden provocar

11. CONSEJOS



Consulte los capítulos sobre seguridad.

11.1 Recomendaciones de cocción

El horno tiene cinco niveles.

Cuente los niveles de las parrillas desde abajo hacia arriba.

El comportamiento de su horno puede ser diferente al del que tenía anteriormente. Las tablas siguientes le proporcionan los ajustes estándares de temperatura, tiempo de cocción y posición de la parrilla.

Si no encuentra los ajustes para una receta especial, busque otra similar.

El horno está dotado con un sistema especial que hace circular el aire y recicla constantemente el vapor. Gracias a este sistema puede cocinar con un entorno de vapor y mantener los alimentos blandos en su interior y crujientes en su exterior. Reduce el tiempo de cocción y el consumo de energía.

Repostería

No abra la puerta del horno antes de que transcurran 3/4 partes del tiempo de cocción establecido.

11.2 Horneado y asado

Si utiliza dos bandejas al mismo tiempo, deje un nivel libre entre ambas.

Carnes y pescados

Utilice una bandeja honda con los alimentos muy grasos para evitar que el horno quede manchado de forma permanente.

Antes de trincar la carne, déjela reposar unos 15 minutos, como mínimo, para que retenga los jugos.







Para evitar que se forme mucho humo en el horno, vierta un poco de agua en la bandeja honda. Para evitar la condensación de humos, añada agua después de cada vez que se seque.

Tiempos de cocción







Los tiempos de cocción dependen del tipo de alimento, de su consistencia y del volumen.







Inicialmente, supervise el rendimiento cuando cocine. Busque los ajustes óptimos (de calor, tiempo de cocción, etc.) para sus recipientes, recetas y cantidades cuando utilice este horno.

RE- POSTERÍA	Cocción convencio- nal		Aire caliente		⏱ (min)	
	 (°C)	 2	 (°C)	 3 (2 y 4)		
Masas batidas	170	2	160	3 (2 y 4)	45 - 60	Molde de pas- tel
Masa con mante- quilla	170	2	160	3 (2 y 4)	20 - 30	Molde de pas- tel
Tarta de queso (con suero)	170	1	165	2	60 - 80	Molde de pas- tel, Ø 26 cm
Strudel	175	3	150	2	60 - 80	Bandeja
Tarta de mermela- da	170	2	165	2	30 - 40	Molde de pas- tel, Ø 26 cm

 RE-POSTERÍA	Cocción convencional		Aire caliente		 (min)	
	 (°C)		 (°C)			
Tronco de Navidad, precaliente el horno vacío	160	2	150	2	90 - 120	Molde de pastel, Ø 20 cm
Pastel de ciruelas, precaliente el horno vacío	175	1	160	2	50 - 60	Molde para pan
Muffins	170	3	140 - 150	3	20 - 30	Bandeja
Muffins, dos niveles	-	-	140 - 150	2 y 4	25 - 35	Bandeja
Muffins, tres niveles	-	-	140 - 150	1, 3 y 5	30 - 45	Bandeja
Galletas	140	3	140 - 150	3	30 - 35	Bandeja
Galletas, dos niveles	-	-	140 - 150	2 y 4	35 - 40	Bandeja
Galletas, tres niveles	-	-	140 - 150	1, 3 y 5	35 - 45	Bandeja
Merengues	120	3	120	3	80 - 100	Bandeja
Merengues, dos niveles, precaliente el horno vacío	-	-	120	2 y 4	80 - 100	Bandeja
Bollos, precaliente el horno vacío	190	3	190	3	12 - 20	Bandeja
Bollos rellenos de crema	190	3	170	3	25 - 35	Bandeja
Bollos rellenos de crema, dos niveles	-	-	170	2 y 4	35 - 45	Bandeja
Tartaletas	180	2	170	2	45 - 70	Molde de pastel, Ø 20 cm
Pastel de fruta	160	1	150	2	110 - 120	Molde de pastel, Ø 24 cm







Precaliente el horno vacío.

 PAN Y PIZZA	Cocción convencional		Aire caliente		 (min)	
	 (°C)		 (°C)			
Pan blanco, 1 - 2 trozos, 0,5 kg cada	190	1	190	1	60 - 70	-

 PAN Y PIZ- ZA	Cocción convencional		Aire caliente		 (min)	
	 (°C)		 (°C)			
Pan de centeno, no se necesita precalentar	190	1	180	1	30 - 45	Molde para pan
Pan/Rollitos, 6 - 8 panecillos	190	2	180	2 (2 y 4)	25 - 40	Bandeja
Pizza	230 - 250	1	230 - 250	1	10 - 20	Bandeja esmaltada
Bollitos	200	3	190	3	10 - 20	Bandeja





Precaliente el horno vacío.







Use el molde de repostería.

 FLANES	Cocción convencional		Aire caliente		 (min)
	 (°C)		 (°C)		
Pudin de pasta, no se necesita precalentar	200	2	180	2	40 - 50
Pudin de verduras, no se necesita precalentar	200	2	175	2	45 - 60
Quiches	180	1	180	1	50 - 60
Lasaña	180 - 190	2	180 - 190	2	25 - 40
Canelones	180 - 190	2	180 - 190	2	25 - 40







Use el segundo nivel.

Utilice la parrilla.

 CARNE	Cocción convencional	Aire caliente	 (min)
	 (°C)	 (°C)	
Carne de res	200	190	50 - 70
Cerdo	180	180	90 - 120
Ternera	190	175	90 - 120
Rosbif poco hecho	210	200	50 - 60
Rosbif en su punto	210	200	60 - 70
Rosbif muy hecho	210	200	70 - 75

 CARNE	Cocción convencional		Aire caliente		 (min)
	 (°C)		 (°C)		
Paletilla de cerdo, con corteza	180	2	170	2	120 - 150
Morcillo de cerdo, 2 trozos	180	2	160	2	100 - 120
Pata de cordero	190	2	175	2	110 - 130
Pollo entero	220	2	200	2	70 - 85
Pavo entero	180	2	160	2	210 - 240
Pato entero	175	2	220	2	120 - 150
Ganso entero	175	2	160	1	150 - 200
Conejo, en trozos	190	2	175	2	60 - 80
Liebre, en trozos	190	2	175	2	150 - 200
Faisán entero	190	2	175	2	90 - 120

Use el segundo nivel.





 PESCADO	Cocción convencional		Aire caliente		 (min)
	 (°C)		 (°C)		
Trucha / Pargo, 3 - 4 pescados	190		175		40 - 55
Atún / Salmón, 4 - 6 filetes	190		175		35 - 60

11.3 Grill

Precalente el horno vacío.

Use el cuarto nivel.

Grill con la temperatura ajustada al máximo.

 GRILL	 (kg)	 (min) 1ª cara	 (min) 2ª cara
	Filetes de solomillo, 4 piezas	0,8	12 - 15
Bistec de vaca, 4 piezas	0,6	10 - 12	6 - 8
Salchichas, 8	-	12 - 15	10 - 12
Chuletas de cerdo, 4 piezas	0,6	12 - 16	12 - 14
Pollo, medio, 2	1	30 - 35	25 - 30
Brochetas, 4	-	10 - 15	10 - 12



GRILL



(kg)



(min)
1ª cara



(min)
2ª cara

Pechuga de pollo, 4 piezas	0,4	12 - 15	12 - 14
Hamburguesas, 6	0,6	20 - 30	-
Filete de pescado, 4 piezas	0,4	12 - 14	10 - 12
Sándwiches tostados, 4 - 6	-	5 - 7	-
Tostadas, 4 - 6	-	2 - 4	2 - 3

11.4 Grill Turbo

Precaliente el horno vacío.

Use el primer o el segundo nivel.

Para calcular el tiempo de asado, multiplique el tiempo de la tabla siguiente por los centímetros de grosor del filete.



RES

CARNE DE



(°C)



(min)

Rosbif o filete, poco hecho	190 - 200	5 - 6
Rosbif o filete, al punto	180 - 190	6 - 8
Rosbif o filete, muy hecho	170 - 180	8 - 10



CERDO



(°C)



(min)

Paletilla / Cuello / Jambón, 1 - 1,5 kg	160 - 180	90 - 120
Chuletas / Costillas, 1 - 1,5 kg	170 - 180	60 - 90
Pastel de carne, 0,75 - 1 kg	160 - 170	50 - 60
Codillo de cerdo precocinado, 0,75 - 1 kg	150 - 170	90 - 120



TERNERA



(°C)



(min)

Ternera asada, 1 kg	160 - 180	90 - 120
Codillo de ternera, 1,5 - 2 kg	160 - 180	120 - 150



CORDERO



(°C)



(min)

Pata de cordero / Cordero asado, 1 - 1,5 kg	150 - 170	100 - 120
Silla de cordero, 1 - 1,5 kg	160 - 180	40 - 60



AVES





(°C)







(min)

Aves troceadas, 0,2 - 0,25 kg cada	200 - 220	30 - 50
Pollo, medio, 0,4 - 0,5 kg cada	190 - 210	35 - 50
Pollo, pularda, 1 - 1,5 kg	190 - 210	50 - 70
Pato, 1,5 - 2 kg	180 - 200	80 - 100
Ganso, 3,5 - 5 kg	160 - 180	120 - 180
Pavo, 2,5 - 3,5 kg	160 - 180	120 - 150
Pavo, 4 - 6 kg	140 - 160	150 - 240

 PESCADO (AL VAPOR)	 (°C)	 (min)
Pescado entero, 1 - 1,5 kg	210 - 220	40 - 60

11.5 Descongelar

	 (kg)	 Tiempo de descongelación (min)	 Tiempo de descongelación posterior (minutos)	
Pollo	1	100 - 140	20 - 30	Coloque el pollo sobre un plato puesto del revés sobre otro mayor. Dele la vuelta a media cocción.
Carne	1	100 - 140	20 - 30	Dele la vuelta a media cocción.
	0.5	90 - 120		
Nata	2 x 0,2	80 - 100	10 - 15	La nata se puede montar perfectamente incluso aunque queden puntos ligeramente congelados.
Trucha	0.15	25 - 35	10 - 15	-
Fresas	0.3	30 - 40	10 - 20	-
Mantequilla	0.25	30 - 40	10 - 15	-
Pasteles	1.4	60	60	-



11.6 Desecar alimentos - Aire caliente



Cubra las bandejas con papel vegetal o de hornear.

Para obtener mejores resultados, pare el horno a la mitad del tiempo de secado, abra la puerta y déjelo enfriar, a ser posible durante una noche para terminar el secado.



Para 1 bandeja, use el tercer nivel.

Para dos bandejas, use el primer y cuarto nivel.

 VERDURAS	 (°C)	 (h)
Judías	60 - 70	6 - 8
Pimientos	60 - 70	5 - 6

 VERDURAS	 (°C)	 (h)
Verduras para sopa	60 - 70	5 - 6
Setas	50 - 60	6 - 8
Hierbas aromáticas	40 - 50	2 - 3

Ajuste la temperatura a 60 - 70 °C.

 FRUTA	 (h)
Ciruelas	8 - 10
Albaricoques	8 - 10
Manzanas en rodajas	6 - 8



Peras

6 - 9

11.7 Horneado húmedo + ventil.. accesorios recomendados

Utilice molde y recipientes oscuros y mates. Tiene mejor absorción del calor que los platos de color claro y brillantes.



Bandeja para pizza

Oscuro, mate
28 cm de diámetro

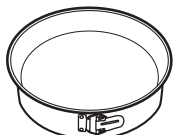

Bandeja para hornear

Oscuro, mate
26 cm de diámetro



Ramequines

Cerámica
8 cm de diámetro,
5 cm de altura













Molde para base

Oscuro, mate
28 cm de diámetro

11.8 Horneado húmedo + ventil.







Para obtener el mejor resultado, siga las recomendaciones de la tabla siguiente.







		 (°C)		 (min)
Rollitos dulces, 12 piezas	bandeja o bandeja honda	175	3	40 - 50
Rollitos, 9 piezas	bandeja o bandeja honda	180	2	35 - 45
Pizza congelada, 0,35 kg	parrilla	180	2	45 - 55
Brazo de gitano	bandeja o bandeja honda	170	2	30 - 40
Brownie	bandeja o bandeja honda	170	2	45 - 50
Soufflé, 6 piezas	ramekin cerámico sobre parrilla	190	3	45 - 55
Base de masa brisé	molde de base sobre parrilla	180	2	35 - 45
Tarta Victoria	bandeja de hornear sobre parrilla	170	2	35 - 50
Pescado pochado, 0,3 kg	bandeja o bandeja honda	180	2	35 - 45
Pescado entero, 0,2 kg	bandeja o bandeja honda	180	3	25 - 35

		 (°C)		 (min)
Filete de pescado, 0,3 kg	molde para pizza sobre parrilla	170	3	30 - 40
Carne pochada, 0,25 kg	bandeja o bandeja honda	180	3	35 - 45
Shashlik, 0,5 kg	bandeja o bandeja honda	180	3	40 - 50
Galletas, 16 piezas	bandeja o bandeja honda	150	2	30 - 45
Mostachones de almendra, 20 piezas	bandeja o bandeja honda	180	2	45 - 55
Muffins, 12 piezas	bandeja o bandeja honda	170	2	30 - 40
Tarta salada, 16 piezas	bandeja o bandeja honda	170	2	35 - 45
Galletas crujientes de masa quebrada, 20 piezas	bandeja o bandeja honda	150	2	40 - 50
Tartaletas, 8 piezas	bandeja o bandeja honda	170	2	30 - 40
Verduras pochadas, 0,4 kg	bandeja o bandeja honda	180	2	35 - 45
Tortilla vegetariana	molde para pizza sobre parrilla	180	3	35 - 45
Verduras mediterráneas, 0,7 kg	bandeja o bandeja honda	180	4	35 - 45

11.9 Información para los institutos de pruebas

Pruebas conforme a IEC 60350-1.

				 (°C)	 (min)	
Pastelillos, 20 unidades por bandeja	Cocción convencional	Bandeja de cocción	3	170	20 - 30	-
Pastelillos, 20 unidades por bandeja	Aire caliente	Bandeja de cocción	3	150 - 160	20 - 35	-
Pastelillos, 20 unidades por bandeja	Aire caliente	Bandeja de cocción	2 y 4	150 - 160	20 - 35	-
Tarta de manzana, 2 moldes, Ø 20 cm	Cocción convencional	Parrilla	2	180	70 - 90	-

				 (°C)	 (min)	
Tarta de manzana, 2 moldes, Ø 20 cm	Aire caliente	Parrilla	2	160	70 - 90	-
Bizcocho, molde de repostería Ø26 cm	Cocción convencional	Parrilla	2	170	40 - 50	Precaliente el horno 10 minutos.
Bizcocho, molde de repostería Ø26 cm	Aire caliente	Parrilla	2	160	40 - 50	Precaliente el horno 10 minutos.
Bizcocho, molde de repostería Ø26 cm	Aire caliente	Parrilla	2 y 4	160	40 - 60	Precaliente el horno 10 minutos.
Mantecados	Aire caliente	Bandeja de cocción	3	140 - 150	20 - 40	-
Mantecados	Aire caliente	Bandeja de cocción	2 y 4	140 - 150	25 - 45	-
Mantecados	Cocción convencional	Bandeja de cocción	3	140 - 150	25 - 45	-
Tostadas, 4 - 6 trozos	Grill	Parrilla	4	máx.	2 - 3 minutos el primer lado; 2 - 3 minutos el segundo	Precaliente el horno 3 minutos.
Hamburguesa de vacuno, 6 trozos, 0,6 kg	Grill	Parrilla y grasera	4	máx.	20 - 30	Coloque la parrilla en el cuarto nivel y la grasera en el tercer nivel del horno. Dele la vuelta a la mitad del tiempo. Precaliente el horno 3 minutos.

12. MANTENIMIENTO Y LIMPIEZA



ADVERTENCIA!

Consulte los capítulos sobre seguridad.

12.1 Notas sobre la limpieza



Agentes limpiadores

Limpie la parte delantera del horno con un paño suave humedecido en agua templada y jabón suave. Limpie y compruebe la junta de la puerta alrededor del interior.

Utilice un producto de limpieza para limpiar las superficies metálicas.

Limpie las manchas con un detergente suave.



Uso diario

Limpie el interior después de cada uso. La acumulación de grasa u otros residuos puede provocar un incendio.

La humedad puede llegar a condensarse en el horno o en los paneles de cristal. Para reducir la condensación, ponga en funcionamiento el horno 10 minutos antes de cocinar. No guarde la comida en el horno más de 20 minutos. Seque el interior con un paño suave después de cada uso.



Accesorios

Limpie todos los accesorios después de cada uso y déjelos secar. Use un paño suave humedecido en agua caliente y detergente suave. No lave los accesorios en el lavavajillas.

No limpie los accesorios no adherentes utilizando un limpiador abrasivo ni objetos afilados.

12.2 Cómo quitar: Apoyos de baldas

Para limpiar el horno, retire los carriles de apoyo.

Paso 1 Apague el horno y espere a que esté frío.

Paso 2 Tire de la parte delantera del carril de apoyo para separarlo de la pared lateral.

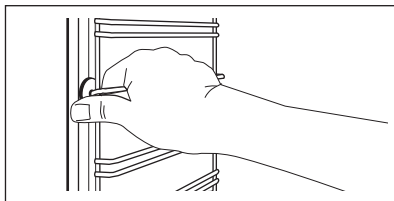

Paso 3 Tire del extremo trasero del carril de apoyo para despegarlo de la pared lateral y sáquelo.

Paso 4 Coloque los carriles de apoyo en el orden inverso. Los pasadores de retención de los carriles telescópicos deben estar orientados hacia la parte frontal.

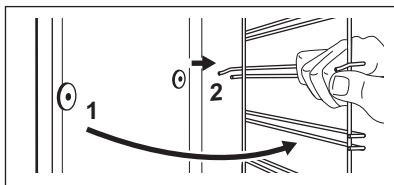

12.3 Instrucciones de uso: Limpieza con agua

Este procedimiento de limpieza utiliza humedad para eliminar las partículas de grasa y alimentos restantes en el horno.

Paso 1 Vierta agua en el relieve del interior. 300 ml.

Paso 2 Ajuste la función: 

Paso 3 Ajuste la temperatura a 90 °C.

Paso 4 Deje funcionar el horno 30 minutos.

Paso 5 Apague el horno.

Paso 6 Espere hasta que el horno esté frío.
Seque el interior con un paño suave.

12.4 Cómo quitar e instalar: Puerta

La puerta del horno tiene dos paneles de cristal. Es posible retirar la puerta del horno y el panel de cristal interior para limpiarlos. Lea las instrucciones completas de "Extracción e instalación de la puerta" antes de retirar los paneles de cristal.



PRECAUCIÓN!

No utilice el aparato sin los paneles de cristal.

Paso 1 Abra completamente la puerta y sujete las dos bisagras.

Paso 2 Levante y gire completamente las palancas de ambas bisagras.

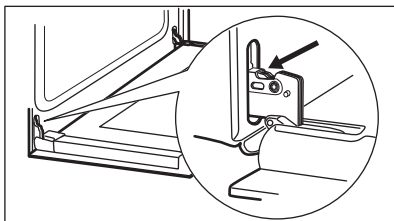

Paso 3 Cierre la puerta del horno a medio camino hasta la primera posición de apertura. A continuación levante la puerta y tire hacia adelante para desengañarla.

Paso 4 Coloque la puerta sobre una superficie estable y protegida por un paño suave.

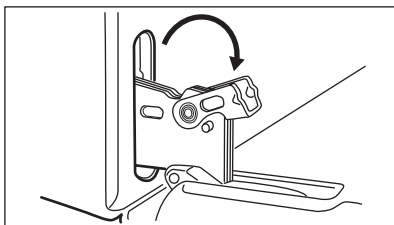

Paso 5 Sujete por ambos lados el acabado de la puerta (B), situado en el borde superior de ésta, y empuje hacia dentro para soltar el sello de resorte.

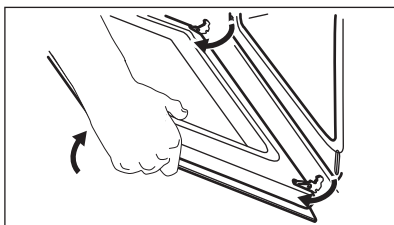

Paso 6 Tire del borde de la puerta hacia delante para desengancharla.

Paso 7 Sujete el panel de la puerta de cristal por el borde superior y extráigalo con cuidado. Asegúrese de que el cristal se desliza completamente fuera de los soportes.

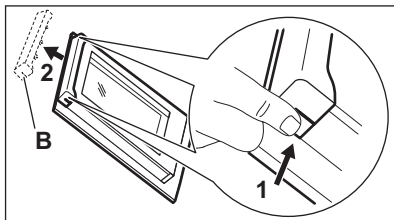

Paso 8 Limpie los paneles de cristal con agua y jabón. Seque los paneles de cristal con cuidado. No limpie los paneles de cristal en el lavavajillas.

Paso 9 Después de la limpieza, instale el panel de vidrio y la puerta del horno.

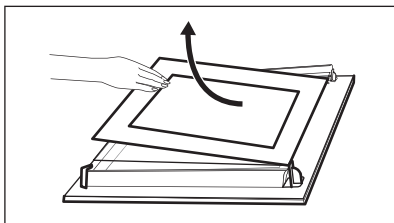

La cara impresa debe mirar hacia el interior de la puerta. Después de la instalación, asegúrese de que la superficie del marco del panel de cristal de las caras impresas no esté áspera cuando la toque. Al instalarlo correctamente, el acabado de la puerta hace clic. Asegúrese de que coloca el panel de cristal interno en los soportes correctos.

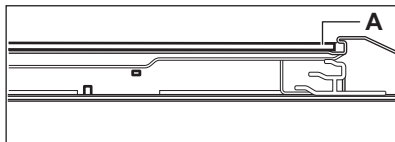

12.5 Cómo cambiar: Bombilla



ADVERTENCIA!

Riesgo de descarga eléctrica.
La lámpara puede estar caliente.

Coja siempre la bombilla halógena con un paño para evitar quemar los residuos de grasa.

Antes de reemplazar la bombilla:

Paso 1	Paso 2	Paso 3
Apague el horno. Espere hasta que el horno esté frío.	Desconecte el horno de la red.	Coloque un paño en el fondo de la cavidad.

Bombilla trasera

Paso 1 Gire la tapa de cristal para extraerla.

Paso 2 Limpie la tapa de cristal.

Paso 3 Cambie la bombilla por otra apropiada termorresistente hasta 300 °C.

Paso 4 Coloque la tapa de cristal.

13. SOLUCIÓN DE PROBLEMAS



ADVERTENCIA!

Consulte los capítulos sobre seguridad.

13.1 Qué hacer si...

En cualquier caso no incluido en esta tabla, por favor contacte con un Centro de Servicio Autorizado.

Problema	Compruebe que...
El horno no calienta.	Ha saltado el fusible.
La junta de la puerta está dañada.	No utilice el horno. Póngase en contacto con un servicio técnico autorizado.

Problema	Compruebe que...
La pantalla muestra "12.00".	Ha habido un corte de alimentación. Ajusta el reloj.
La bombilla no funciona.	La bombilla se ha fundido.

Los datos que necesita para el centro de servicio técnico se encuentran en la placa de características. La placa de régimen se encuentra en el marco delantero de la cavidad del horno. No retire la placa de características de la cavidad del horno.

13.2 Datos de servicio

Si no logra subsanar el problema, póngase en contacto con su distribuidor o el centro de servicio técnico.

Es conveniente que anote los datos aquí:

Modelo (MOD.)

Número de producto (PNC)

Número de serie (S.N.)

14. EFICACIA ENERGÉTICA

14.1 Información del producto y Hoja de información del producto*

Nombre del proveedor	Electrolux	
Identificación del modelo	EOF3H54X 949496302 KOFGH54X 949496300	
Índice de eficiencia energética	81.2	
Clase de eficiencia energética	A+	
Consumo de energía con carga estándar, modo convencional	0.93 kWh/ciclo	
Consumo de energía con carga estándar, modo con ventilador	0.69 kWh/ciclo	
Número de cavidades	1	
Fuente de calor	Electricidad	
Volumen	72 l	
Tipo de horno	Horno empotrado	
Masa	EOF3H54X	27.8 kg
	KOFGH54X	27.5 kg

* Para la Unión Europea según los Reglamentos de la UE 65/2014 y 66/2014.

Para la República de Bielorrusia según STB 2478-2017, apéndice G; STB 2477-2017, anexos A y B.

Para Ucrania según 568/32020.

La clase de eficiencia energética no es aplicable a Rusia.

EN 60350-1 - Aparatos electrodomésticos - Parte 1: Placas, hornos, hornos de vapor y parrillas - Métodos para medir el rendimiento.

14.2 Ahorro de energía



El horno tiene características que le ayudan a ahorrar energía durante la cocina de cada día.

Asegúrese de que la puerta del horno está cerrada cuando el horno funciona. No abra la puerta del horno muchas veces durante la cocción. Mantenga limpia la junta de la puerta y asegúrese de que está bien fijada en su posición.

Utilice utensilios de cocina de metal para mejorar el ahorro energético.

En la medida de lo posible, no precaliente el horno antes de cocinar.

Reduzca al máximo el tiempo entre horneados cuando prepare varios platos de una vez.

Cocción con ventilador

En la medida de lo posible, utilice las funciones de cocción con ventilador para ahorrar energía.

Calor residual

Para una duración de la cocción superior a 30 minutos, reduzca la temperatura del horno un mínimo de 3 - 10 minutos antes de que transcurra el tiempo de cocción. El calor residual dentro del horno seguirá cocinando.

Utilice el calor residual para calentar otros platos.

Mantener calor

Si desea utilizar el calor residual para mantener calientes los alimentos, seleccione el ajuste de temperatura más bajo posible.

Horneado húmedo + ventil.

Función diseñada para ahorrar energía durante la cocción.

Cuando se utiliza esta función, la bombilla está apagada.

15. ASPECTOS MEDIOAMBIENTALES

Recicle los materiales con el símbolo . Coloque el material de embalaje en los contenedores adecuados para su reciclaje. Ayude a proteger el medio ambiente y la salud pública, así como a reciclar residuos de aparatos eléctricos y electrónicos. No

deseche los aparatos marcados con el símbolo  junto con los residuos domésticos. Lleve el producto a su centro de reciclaje local o póngase en contacto con su oficina municipal.

A series of 20 horizontal dotted lines for writing.



CE

867360149-A-342020